

FEATURES & SPECIFICATIONS

INTENDED USE

The Alcon Lighting Veria 8012 High Bay Fluorescent Commercial Lighting Pendant is the ideal solution for conference room, warehouse, or office lighting applications where powerful high bay lighting is desired. Attractive, efficient lighting is good for your brand too.

ADDITIONAL FEATURES

- 120" field adjustable flexible cable with aircraft cable supports comes standard
- Rigid stem mount options available; does not include aircraft cable; Maximum allowable stem length is 10 FT
- Acrylic Shade
- Optional bottom lenses are available for enclosing the fixture
- Housing / Cord finish options: Black, White or Silver
- CSA Listed. Suitable for Damp Locations.
- 120V

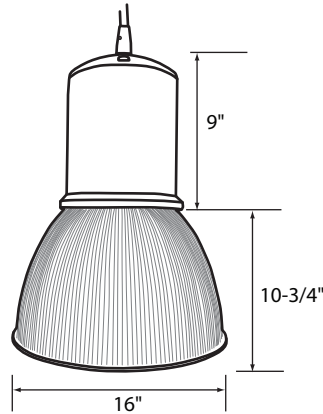

Listings:



Ordering Information:

Example: (8012-2-42-AM-B)

Model	# of Lamps	Wattage	Finish	Options
8012	1 1 Lamp	13 13 Watts	B Black	CAPD ² Conical Acrylic Prismatic Drop Lens
	2 2 Lamp	18 18 Watts	W White	SAF ² Smooth Acrylic Flat Lens
	3 3 Lamp	26 26 Watts	S Silver	RS12 ¹ 12" Rigid Stem
	4 4 Lamp	32 32 Watts		RS18 ¹ 18" Rigid Stem
		42 42 Watts		RS36 ¹ 36" Rigid Stem
				RS60 ¹ 60" Rigid Stem

¹ Rigid stem mount finish matches housing finish. ² To enclose fixture; Clamp included.