

FEATURES & SPECIFICATIONS

INTENDED USE

The Alcon Lighting Santorini 8010 High Bay Fluorescent Commercial Lighting Pendant is the ideal solution for conference room, warehouse, or office lighting applications where powerful high bay lighting is desired. Attractive, efficient lighting is good for your brand too.

ADDITIONAL FEATURES

- 120" field adjustable flexible cable with aircraft cable supports comes standard
- Rigid stem mount options available; does not include aircraft cable; Maximum allowable stem length is 10 FT
- Frosted Glass lens encloses the bottom, reducing glare
- Housing / Cord finish options: Black, White or Silver
- cCSAus Certified to UL Standards. Suitable for damp location
- 120/277V

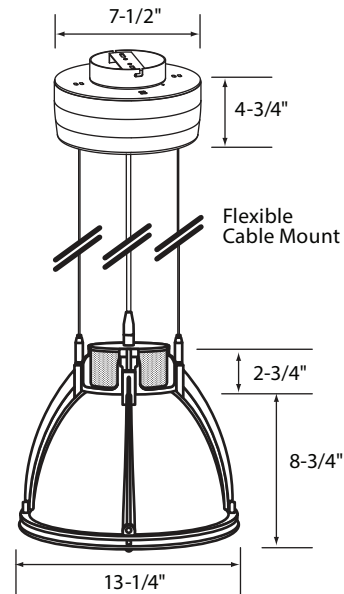

Listings:



Ordering Information:

Example: (8010-1-42-AM-B)

Model	# of Lamps	Wattage	Shade Finish	Housing/Cord Finish	Options
8010	1 1 Lamp	13 13 Watts	AM Amber	B Black Housing/ Black Cord	RS12 ¹ 12" Rigid Stem
		18 18 Watts	BL Blue	P White Housing/ White Cord	RS18 ¹ 18" Rigid Stem
	26 26 Watts	WH White	RS36 ¹ 36" Rigid Stem		
	32 32 Watts	RD Red	S Silver Housing/ Silver Cord		RS60 ¹ 60" Rigid Stem
	42 42 Watts				

¹ Rigid stem mount finish matches housing finish