

8 7 6 5 4 3 2 1

ITEM NO.	PART NUMBER	DESCRIPTION	SLPMW48L132MVH/SL PMW48LART132MVH/ QTY.
1	SL_REF_1LT_48IN_UPL	REV 1	1
2	SL_EC_PLATE	REV 1	2
3	SLPMW48L	REV 0	1
4	SL_SB_1LT_T8	REV 0	2
5	SL_WW	REV 0	2
6	SL_ACCESS_PANEL	REV 1	2
7	SL_WIRE_ACC_PL	REV 0	4
8	SL_LENS	REV 0	1

D

C

B

A

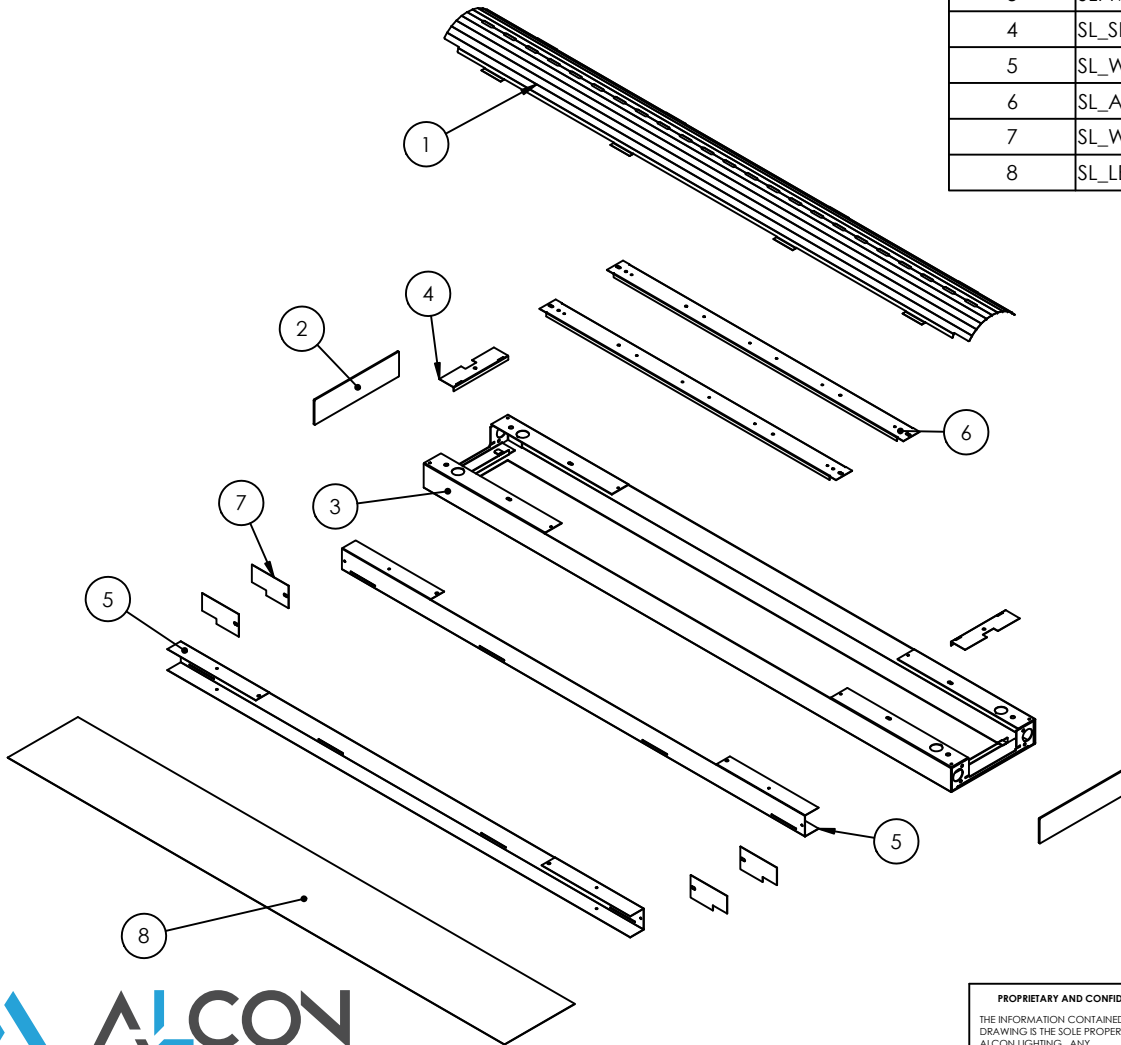

EC PLATES CAN BE REMOVED TO CONTINUOUS RUN THE FIXTURES

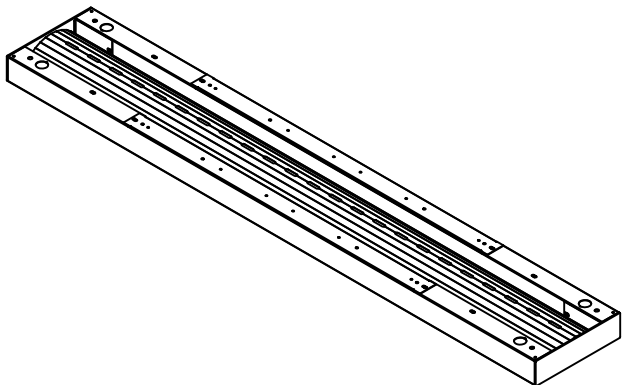

D

C

B

A



**PROPRIETARY AND CONFIDENTIAL**  
 THE INFORMATION CONTAINED IN THIS DRAWING IS THE SOLE PROPERTY OF ALCON LIGHTING. ANY REPRODUCTION IN PART OR AS A WHOLE WITHOUT THE WRITTEN PERMISSION OF ALCON LIGHTING IS PROHIBITED.

UNLESS OTHERWISE SPECIFIED:		NAME	DATE	TITLE:
DIMENSIONS ARE IN INCHES		DRAWN		
TOLERANCES:		CHECKED		
FRACTIONAL: 1/32		ENG APPR.		
ANGULAR: ±1°		MFG APPR.		
TWO PLACE DECIMAL: ±0.020		Q.A.		SIZE
THREE PLACE DECIMAL: ±0.010		COMMENTS:		DWG. NO.
MATERIAL VARIES				NLP12113MW4FT
FINISH				REV
DO NOT SCALE DRAWING				0
		SCALE: 1:8	WEIGHT:	SHEET 1 OF 3

8 7 6 5 4 3 2 1

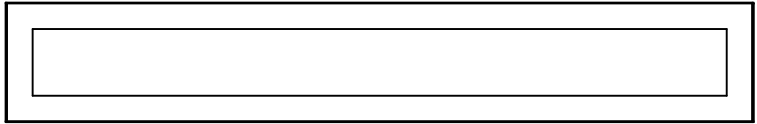
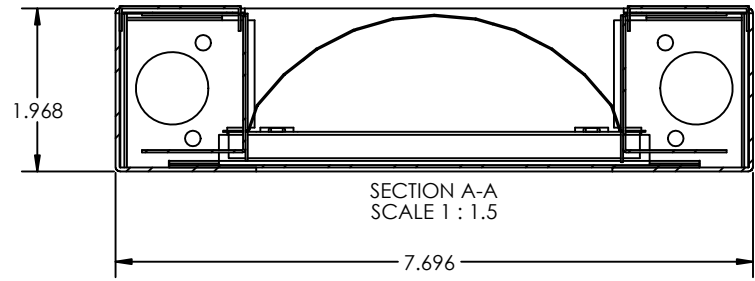
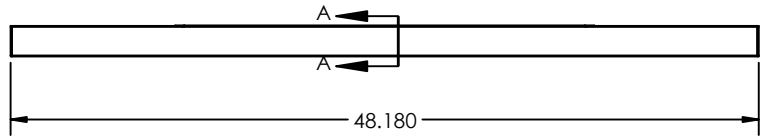
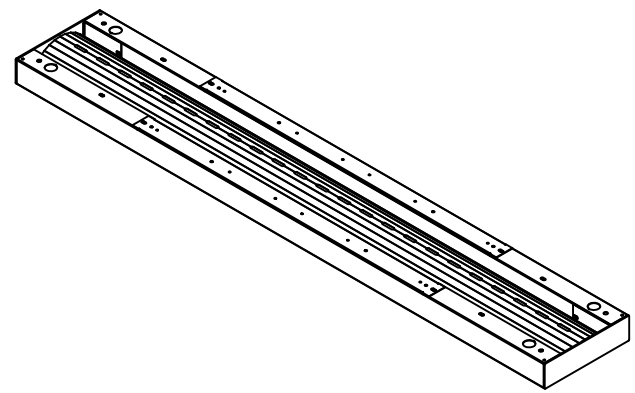
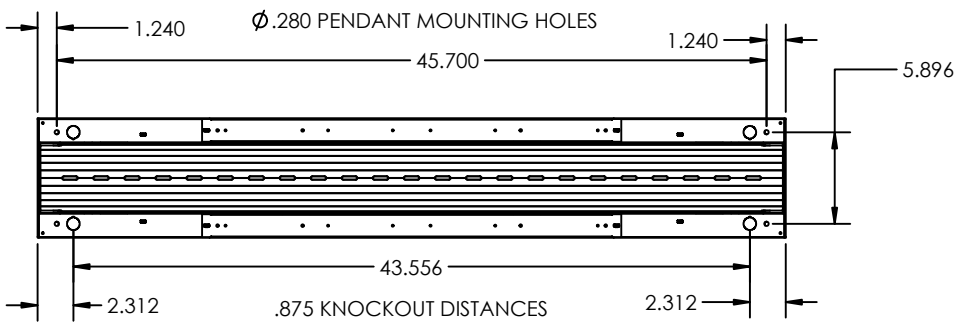

**PROPRIETARY AND CONFIDENTIAL**  
 THE INFORMATION CONTAINED IN THIS DRAWING IS THE SOLE PROPERTY OF ALCON LIGHTING. ANY REPRODUCTION IN PART OR AS A WHOLE WITHOUT THE WRITTEN PERMISSION OF ALCON LIGHTING IS PROHIBITED.

UNLESS OTHERWISE SPECIFIED:		NAME	DATE		
DIMENSIONS ARE IN INCHES		DRAWN			
TOLERANCES:		CHECKED			
FRACTIONAL $\pm 1/32$		ENG APPR.		TITLE:	
ANGULAR: $\pm 1^\circ$		MFG APPR.			
TWO PLACE DECIMAL $\pm .020$		Q.A.			
THREE PLACE DECIMAL $\pm .010$		COMMENTS:			
MATERIAL VARIES				SIZE	DWG. NO.
FINISH				<b>B</b>	NLP12113MW4FT
DO NOT SCALE DRAWING				SCALE: 1:8	WEIGHT:
				SHEET 2 OF 3	
				REV	0

8 7 6 5 4 3 2 1

D

C

B

A

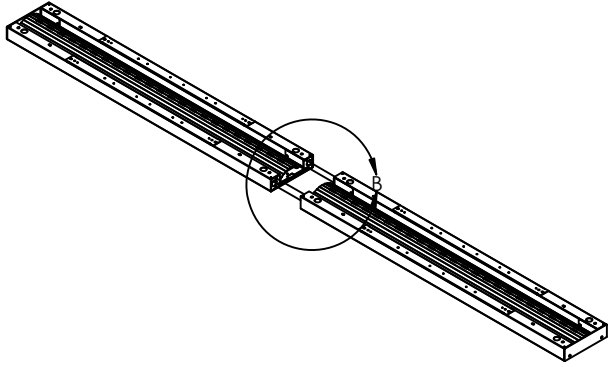

DETAIL B  
SCALE 1:2

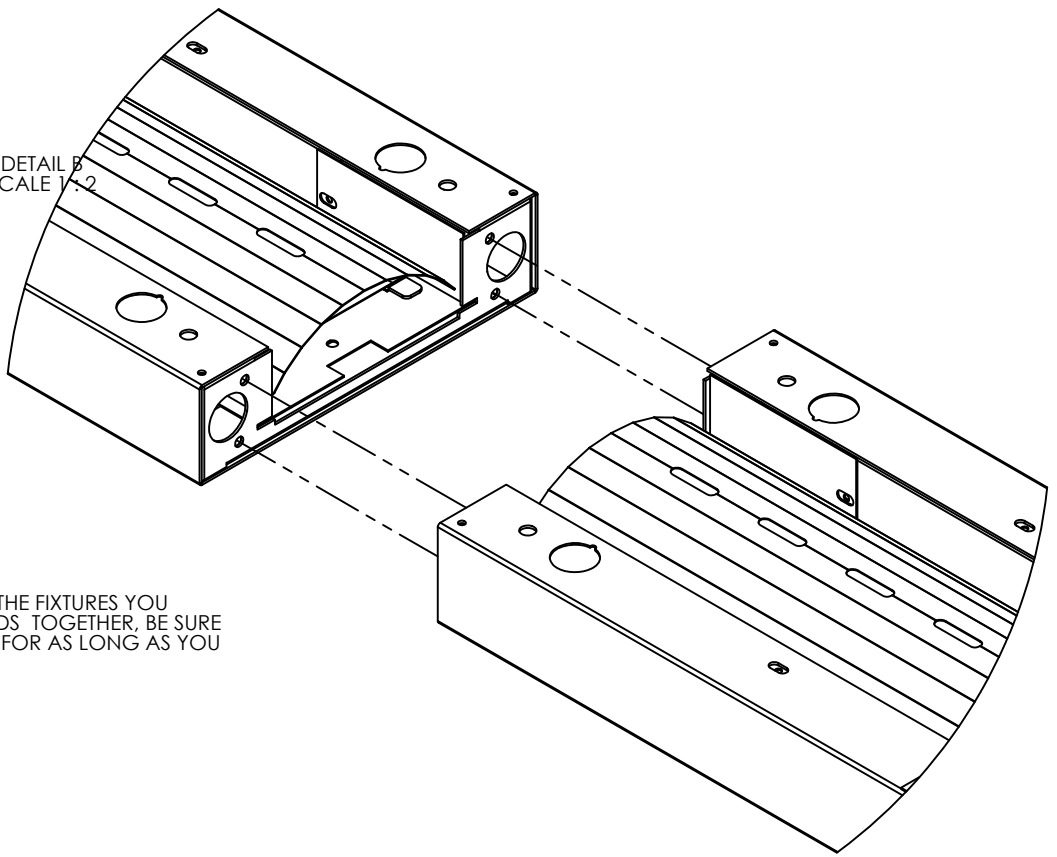

TO CONTINUOUS RUN THE FIXTURES, FIRST REMOVE THE EC PLATES ON THE ENDS OF THE FIXTURES YOU WANT TO ATTACH TOGETHER. THEN USING BOLTS AND NUTS (4X) ATTACH THE TWO ENDS TOGETHER, BE SURE BOTH FIXTURES ARE PROPERLY ALIGNED BEFORE TIGHTENING THE BOLTS. REPEAT STEPS FOR AS LONG AS YOU WOULD LIKE TO CONTINUOUS RUN THE FIXTURES.



8 7 6 5 4 3 2 1

**PROPRIETARY AND CONFIDENTIAL**  
THE INFORMATION CONTAINED IN THIS DRAWING IS THE SOLE PROPERTY OF ALCON LIGHTING. ANY REPRODUCTION IN PART OR AS A WHOLE WITHOUT THE WRITTEN PERMISSION OF ALCON LIGHTING IS PROHIBITED.

UNLESS OTHERWISE SPECIFIED:		NAME	DATE	TITLE:	
DIMENSIONS ARE IN INCHES		DRAWN	B.ELLZEY		10/4/2016
TOLERANCES:		CHECKED			
FRACTIONAL: $\pm 1/32$		ENG APPR.			
ANGULAR: $\pm 1^\circ$		MFG APPR.			
TWO PLACE DECIMAL: $\pm 0.020$		Q.A.			
THREE PLACE DECIMAL: $\pm 0.010$		COMMENTS:			
MATERIAL VARIES					
FINISH					
DO NOT SCALE DRAWING					
SIZE	DWG. NO.	REV			
<b>B</b>	NLP12113MW4FT	0			
SCALE: 1:8	WEIGHT:	SHEET 3 OF 3			

D

C

B

A