

Project Name:

Type:

Quantity:

**FIXTURE SPECIFICATIONS**

**INTENDED USE**

The 5" adjustable commercial-grade LED floodlight is ideal for outdoor lighting. Made of high-grade, diecast metal housing with a glare-free aluminum reflector lens, our powerful lighting fixture comes with a capacity for 50,000 hours of light. The product is rated for both wet and damp locations, mounting on surfaces for industrial uplighting.

**FEATURES**

**Construction:** Die-cast aluminum housing secured with tamper resistant stainless steel screws

**Gasket:** Sealed with high-grade weatherproof silicone gasket

**Finish:** Black

**Voltage:** 120/277V

**Wattage:** 27W

**Lumens:** 1000 lms

**Life:** 50,000 hours

**CRI:** 80

**Warranty:** 5 year carefree for parts & components (labor not included)

**Listings:** cETLus, Assembled in USA, Title 24 JA8 Compliant, IP65 Rated

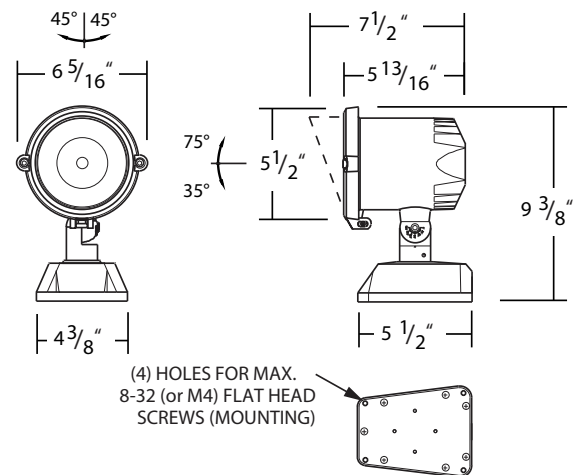

**ORDERING INFORMATION** Example: (9161-OP-30K-15)

Model	FacePlate	Color Temperature	Beam Spread	Options
<b>9161</b>	<b>OP</b>	<b>30K</b>	<b>15</b>	<b>TR</b>
	Open	3000K	15°	Tree Strap
	<b>VI</b>	<b>40K</b>	<b>30</b>	<b>GR</b>
	Visor	4000K	30°	Ground Spike
			<b>45</b>	
			45°	



Shown with Visor