

FIXTURE SPECIFICATIONS

INTENDED USE

The specification grade 9115 Architectural Landscape LED Low Voltage Stainless Steel In Ground Well Light features a durable, tempered lens and a silicone sealed gasket to protect from water, moisture, and insects. The 9115 is an ideal solution for landscape applications looking for quality and energy efficient lighting.

FEATURES

- Max Load:** 2000lbs
- Connection:** 20" 18AWG Lead Wire
- Voltage:** 24V DC Power Supply Required
- Wattage:** 2 Watts
- Lumens:** 160lms
- CRI:** 85+
- Beam Spread:** 25°
- Warranty:** 3 Years Carefree for Parts & Components (Labor Not Included)
- Listings:** cETLus, Wet Location IP65
- Operating Temperature:** -4 ~ 122°F (-20 ~ 50°C)
- Ambient Temperature:** -4 ~ 176°F (-20 ~ 80°C)

Dimmable
24V DC Power Supply Required

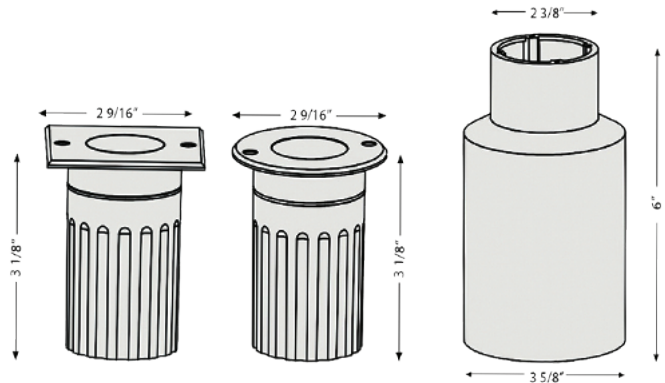

ORDERING INFORMATION Example: (9115-R-30K)

Model	Shape	Color Temperature
9115	R	30K
	S	40K
		3000K
		4000K