

FEATURES & SPECIFICATIONS

INTENDED USE

The **Jacinto Landscape Architectural LED Path Light** is designed with durable, heat resistant lens and a silicone sealed gasket to protect from water, moisture, and insects. The Jacinto is an ideal solution for landscape applications looking for quality and energy efficient lighting.



DETAILS

- Shroud:** W 1.75" x L 4.75" (6.25" Fully Extended)
- Stem:** Solid Brass 24" Pipe with 1/2" NPT on Bottom
- Construction:** Corrosion Resistant Cast Brass
- Lens:** Clear and Heat Resistant Flat Glass
- Socket:** Top Grade Ceramic Bi-Pin Socket with Retention Clip
- Silicone Gasket:** Weather Tight Protection
- Mounting:** Standard Injection Molded Spike with 1/2" NPT Threaded Female Hub
- Wiring:** 3 FT 18-2 Direct Burial Cord
- Electrical:** Remote 12V Transformer Required
- Lamp Equivalent:** 12V MR11 Halogen 35W Max
- Beam Spread:** 40° Flood
- Finish:** Gun Metal

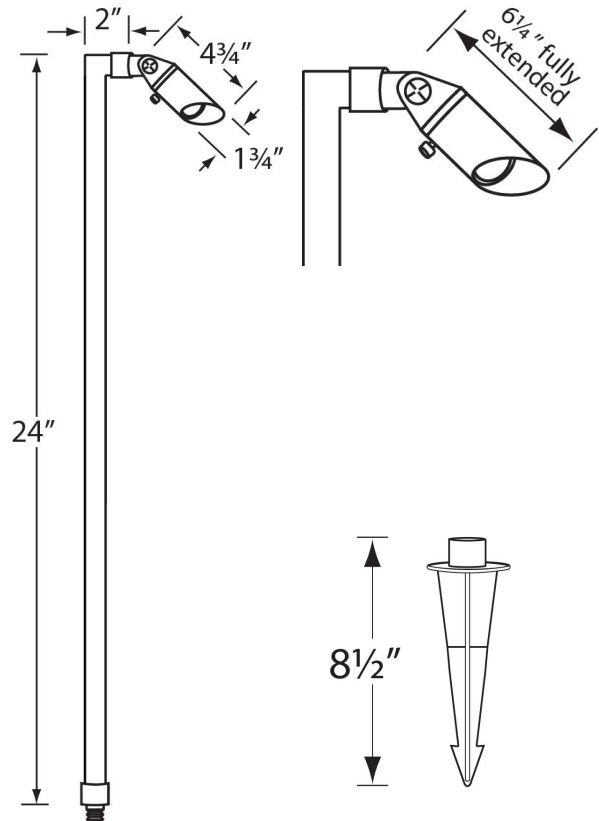

ADDITIONAL FEATURES

- Voltage:** 12V
- Wattage:** 3W
- Lumens:** 220 lms
- Color Temperature:** 2700K
- Life:** 40,000 Hours
- Listings:** Limited Lifetime Warranty on Housing and Stem
5 Years Warranty on LED Component

Ordering Information:

Example: (9106)

Model

9106