

FIXTURE SPECIFICATIONS

INTENDED USE

Add maximize light output with this stainless steel in-ground well light. Featuring a tempered glass lens and grill to protect from natural hazards, our light applies to most locations, soil and concrete. Also available with RGBW color tuning technology.

DETAILS

D 10.25" x **W** 10.25" x **H** 14.38"

Construction: Stainless Steel w/ PVC Sleeve

Installation: Rated for In-Ground Soil and Concrete Applications

Lens: Clear, Heat Resistant, Tempered Glass

ADDITIONAL FEATURES

Life: 35,000 Hours
Listing: ETL Approved for Wet Location
Lamp Type: PAR38 LED Included
CRI: 80+

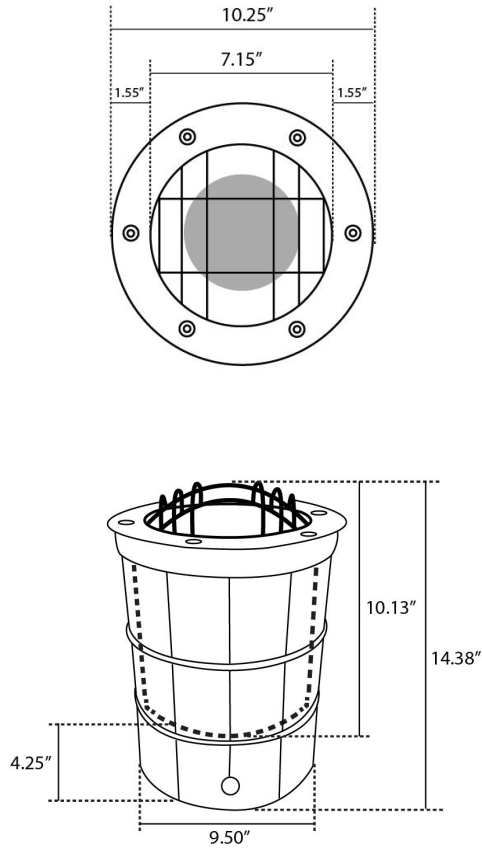

ORDERING INFORMATION Example: (9095-RGBW)

Model	Lamp Type	Color Temp
9095	RGBW 15W 1300 lms 120° Beam Spread 120V	(Blank) RGB + W (27-64K)
W-25	White 12.5W 1200 lms 25° Beam Spread 120-277V	27K 2700K
W-40	White 12.5W 1200 lms 40° Beam Spread 120-277V	30K 3000K 40K 4000K 50K 5000K