

Project Name: _____ Type: _____ Quantity: _____

INTENDED USE

This versatile in-grade well uplight delivers exceptional performance for accentuating trees, shrubs, and pathways while enhancing safety in residential and commercial landscapes. Featuring a durable cast brass finish, it ensures solid construction and long-lasting illumination. Designed for reliability, the fixture includes an anti-moisture migration connection, a waterproof sealed enclosure, and a warm white LED color temperature ideal for landscape lighting.

FEATURES

W 4.875" x L 4.625" x Dia 4.875"

Construction: Injected Molded Composite for High UV Stability

Finish: Cast Brass

Lens: Clear and Heat resistant Flat Glass Driver-Over Rated for 3000LBS

Faceplate: Cast Brass with Heat Dissipative Holes

Socket: Top Grade Adjustable (25°) Ceramic Bi-Pin Socket with Retention Clip and Teflon-Jacketed Wire Lead

Gasket: Weather Tight Protection

Wiring: Pre-Wired with a 3 FT 18-2 SJT-W Direct Burial Cord

Mounting: In-Ground Direct Burial or Concrete Encasement

Voltage: 12V

Wattage: 5W

Color Temperature: 27/30/40/50K

Lumens: 500 lm

CRI: 80+

Life: 50,000 Hrs

Warranty: 5 years Carefree for parts & components (Labor not included)

Listings: cETLus Listed, Wet Location

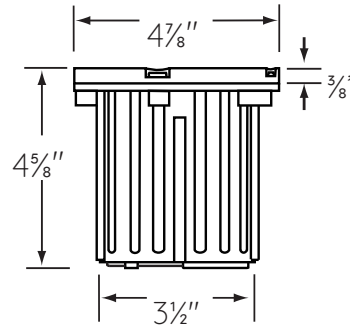
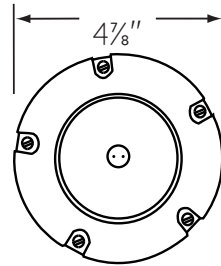

Alcon Lighting 9026 Low-Voltage 5-Inch Adjustable In-Ground LED Well Light



ORDERING INFORMATION Example:

| Model | Color Temp | | Finish | | Options | |
|-------|------------|-------|--------|-----------------|---------|-------------------|
| 9026 | 27K | 2700K | AB | Antique Bronze | CPK | Concrete Pour Kit |
| | 30K | 3000K | GM | Gun Metal | | |
| | 40K | 4000K | SS | Stainless Steel | | |
| | 50K | 5000K | | | | |