

Project Name: _____ Type: _____ Quantity: _____

INTENDED USE

The Nolan 9021 is the ideal solution for outdoor well lighting applications. Assembled in the U.S.A. with a body of cast brass or 316 Grade stainless steel. The product matches functionality, design, and consistent quality. All materials and finishes are specially chosen and applied for a long lasting fixture.

SIZE

H 15 3/4" x Dia 3 7/8"

ADDITIONAL FEATURES

Construction: Cast Brass fixture. PVC Sleeve includes stainless steel retention clips.

Color Temperature: 2700K Warm White

Voltage: 12V AC/DC

CRI: 80

Ambient Temperature: -22F° to +122F°

Wiring: 3' 18-2 SJTW Burial Cord comes standard

Mount in-ground direct burial or concrete encasement

Electrical: Remote 12V Transformer Required

Limited Lifetime Warranty on Fixture only
5 year Warranty on LED

Dimmable

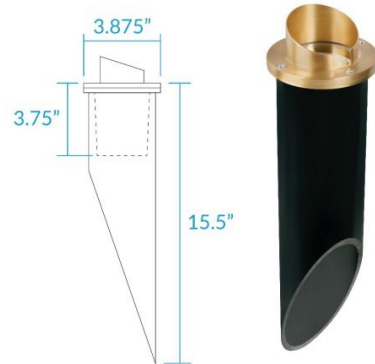

Ordering Information Example: (9021-SS-5W27K15-PVC)

Model	Finish	Wattage Lumens Color Temp Beam	Options
9021	SS Stainless Steel	5W27K15 5 watts / 450 lms / 2700K / 15° Spot	PVC PVC Sleeve
	AB Antique Bronze Cast	5W27K45 5 watts / 450 lms / 2700K / 45° Flood	
	BA Brass Black Aluminum	5W27K60 5 watts / 450 lms / 2700K / 60° Wide Flood	
	NB Natural Brass	5W30K15 5 watts / 470 lms / 3000K / 15° Spot	
	BC Black Composite	5W30K38 5 watts / 470 lms / 3000K / 38° Flood	
		5W30K60 5 watts / 470 lms / 3000K / 60° Wide Flood	