

Project Name: _____ Type: _____ Quantity: _____

INTENDED USE

The Landscape Architectural LED Drive-Over Rated Well Light is designed with durable, tempered lens and a silicone sealed gasket to protect from water, moisture, and insects. The 9020 is an ideal solution for landscape applications looking for quality and energy efficient lighting.

FEATURES

- W** 3.875" x **L** 14.5" x **Dia** 3.875"
- Construction:** Fixture Mounted with Stainless Steel Retention Clips Inside PVC Sleeve
- Lens:** Clear, Tempered, and Heat Resistant Convex Glass Extra Flat Lens Included
- Wiring:** Prewired with a 3' 18-2 SPT2-W direct burial cord
- Socket:** Top grade ceramic bi-pin with retention clip
- Gasket:** Weather Tight Protection
- Mounting:** In-Ground Direct Burial or Concrete Encasement
- Voltage:** 12V
- Wattage:** 5W
- Color Temperature:** 27/30/40/50K
- Lumens:** 500 lm
- CRI:** 80+
- Life:** 50,000 Hrs
- Warranty:** 5 years Carefree for parts & components (Labor not included)
- Listings:** cETLus Listed, Wet Location

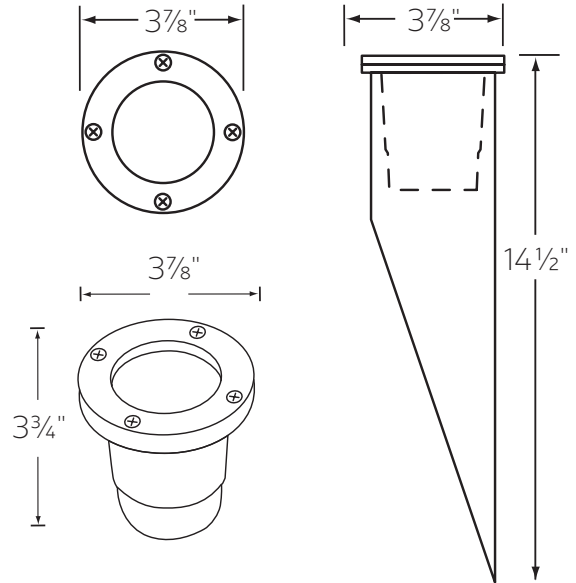

Alcon Lighting 9020 Low-Voltage 4-Inch In-Ground LED Well Light



ORDERING INFORMATION Example:

Model	Finish	Color Temp	Options
9020	CB Cast Brass	27K 2700K	PVC PVC Sleeve
		30K 3000K	
	40K 4000K		
	50K 5000K		
	SS Stainless Steel		