

Project Name:

Type:

Quantity:

FIXTURE SPECIFICATIONS

INTENDED USE

The marine and specification-grade architectural submersible pond and fountain LED light for underwater applications offers quality lighting with adjustable, cast brass or stainless steel corrosion-resistant light. Includes water-resistant cord.

FEATURES

Construction: Cast brass or Stainless Steel with 316 Marine Grade screws

Wattage: 5 Watt

Lumens: 470lms

Voltage: 9V-17V

Life: 50,000 Hours

Listings: IP68 suitable for fountains, ponds, and waterfalls. Do not use in swimming pools, lakes or spas.

Warranty: 5 Years Carefree for Parts & Components (Labor Not Included)

Pre-Wired with 30-ft 16/2 water resistant cord

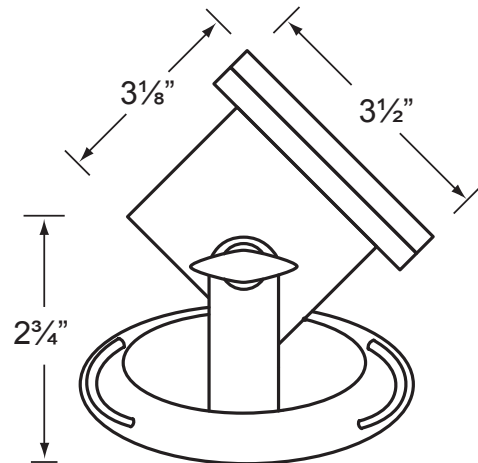

Alcon 17006 Submersible Pond and Fountain Underwater LED Light



ORDERING INFORMATION Example: (17006-27K-15-AB)

Model	Color Temperature		Beam Spread		Finish	
17006	27K	2700K	15	15° Spot	AB	Antique Bronze
	30K	3000K	38	38° Flood	SS	Stainless Steel
			60	60° Wide Flood	NB	Natural Brass