

14079 INSTALLATION INSTRUCTIONS

IMPORTANT SAFETY INSTRUCTIONS

• **WARNING** - Risk of fire or electric shock. LED Retrofit Kit installation requires knowledge of luminaire electrical systems. If not qualified, do not attempt installation. Contact a qualified electrician.

Attention: Risque d'incendie ou de choqe électrique. La rénovation de l'installation du Kit nécessite des connaissances dans les systèmes électriques. Si vous n'êtes pas qualifié, ne tentez pas cette manipulation d'installation. Contactez un électricien qualifié.

• **WARNING** - Risk of fire or electric shock. Install these kits only in the luminaires that has the construction features and dimensions shown in the photographs and/or drawings.

Attention: Risque d'incendie ou de choqe électrique. Installer ces kits seulement avec les luminaires qui ont les mêmes caractéristiques et les dimensions que préconise le constructeur. Voir les illustrations (dessins ou photographies).

• **WARNING** - To prevent wiring damage or abrasion, do not expose wiring to edges of sheet metal or other sharp objects.

Attention: Pour prévenir des risques d'usures anormales du produit, ne pas mettre celui ci proche de surfaces coupantes.

• Do not make or alter any open holes in an enclosure of wiring or electrical components during kit installation.

• **WARNING -RISK OF FIRE OR ELECTRIC SHOCK. DO NOT ALTER, RELOCATE, OR REMOVE WIRING, LAMP HOLDERS, POWER SUPPLY, OR ANY OTHER ELECTRICAL COMPONENTS.**

Attention: Risque d'incendie ou de choqe électrique. NE PAS MODIFIER LE PRODUIT (DOUILLE, CABLAGE ETC...) OU CHANGER L'UTILISATION PRINCIPALE DU PRODUIT OU TOUT AUTRE COMPOSANTS DU PRODUIT!

• **WARNING -RISK OF FIRE OR ELECTRIC SHOCK. INSTALLATION OF THIS RETROFIT ASSEMBLY REQUIRES A PERSON FAMILIAR WITH THE CONSTRUCTION AND OPERATION OF THE LUMINAIRE'S ELECTRICAL SYSTEM AND THE HAZARD INVOLVED. IF NOT QUALIFIED, DO NOT ATTEMPT INSTALLATION. CONTACT A QUALIFIED ELECTRICIAN.**

Attention: Risque d'incendie ou de choqe électrique. CE TYPE DE MODERNISATION D'INSTALLATION DEMANDE UNE PERSONNE COMPETENTE EN ELECTRICITE ET QUALIFIE DANS LES LUMINAIRES. ATTENTION DES RISQUES POUR LE PRODUIT ET POUR LA PERSONNE SONT IMPORTANTS EN CAS DE NON RESPECT DE CES PREVENTIONS. Si vous n'êtes pas qualifié, ne tentez pas cette manipulation d'installation. Contactez un électricien qualifié.

• **CAUTION:SHOCK AND FIRE HAZARD,DO NOT USE WHEN ENCLOSURE IS BROKEN.**

• SUITABLE FOR USE IN ENCLOSED RECESSED LUMINAIRES.

• MIN.LAMP COMPARTMENT DIMENSIONS-4(D)-X 5.5(H) inch" where D is minimum diameter and H is minimum height of Listed Recessed luminaire Compartment,as applicable.

• SUITABLE FOR TYPE IC OR SUITABLE FOR TYPE NON-IC.

• SUITABLE FOR DAMP LOCATIONS

• SUITABLE FOR WET LOCATIONS

• Maximum of 8 pcs of NO.12 AWG through branch circuit conductor.

NOTES:

1. Before starting or installation, please read this leaflet and keep it for future reference.

2. To avoid possible electrical shock, be sure that power supply is turned off at fuse box or circuit breaker before installing or servicing fixture.

3. During installation do not let the product surface rub against other hard objects or dropped on the floor, otherwise the product will be damaged.

4. Risk of fire supply conductors (power wires) connecting the fixture must be rated minimum 90°C if uncertain. consult an Electrician.

5. The luminaire must be securely mounted; the bare wires of the power cord must be properly insulated to prevent electrical hazards.

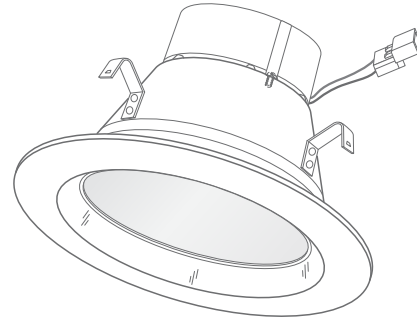

6. For indoor use only, suitable for damp locations, avoid the light and its power supply to contact with water and other liquids in order to avoid leakage, electric shock situations.

7. Protect the light from dust and dirt when painting or during construction.

8. Clean with a soft damp cloth only, do not use any chemical cleaners.

9. Installation of any recessed lighting luminaire check your local electrical code. This code sets the wiring standards for your locality and should be carefully studied before starting.

10. The luminaire light can be dimmed with standard triac dimmer.

11. Power: 9W

INSTALLATION INSTRUCTIONS

RECESSED HOUSING AND DIMMER COMPATIBILITY

• LED Retrofit Luminaire is designed to install in standard 4" recessed downlight housing.

• Recommended dimmer such as Lutron and Leviton.

• Compatibility of housing not on this list may be determined by measurement of the housing as detailed in the attached drawing (Figure 1)

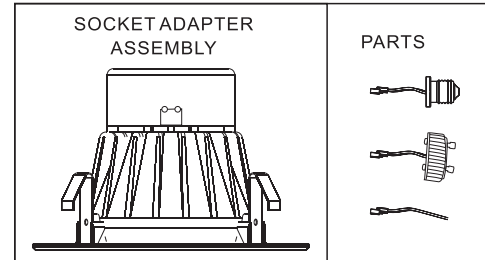
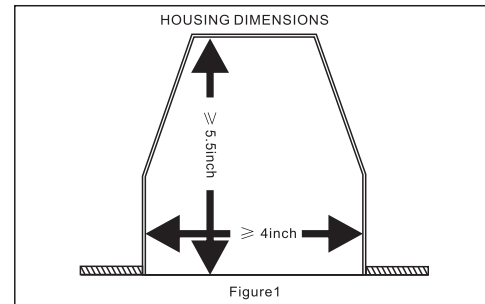

14079 INSTALLATION INSTRUCTIONS

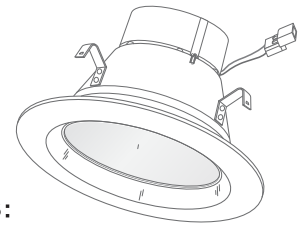
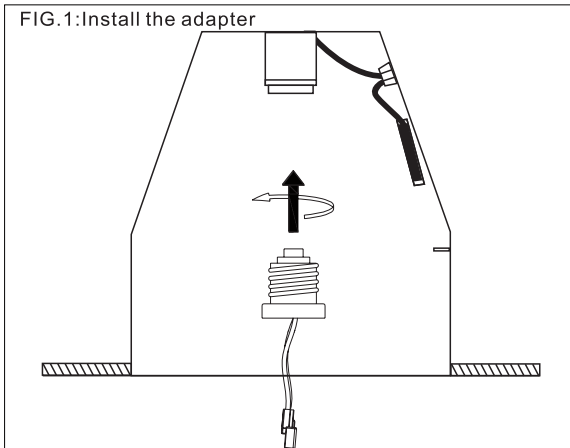

FIG.1:Install the adapter



INSTALLATION INTO HOUSINGS:

1. Thread the socket adapter into the socket.(FIG. 1)
2. Plug the female connector of the retrofit trim onto the male connector of the socket adapter assembly.(FIG.2)
If existent housing with holdbase can not compatible,need to relocate.Connect wire black to L,White to N.
3. Tuck all wires into the can and carefully push the retrofit trim into can (note:to provide enough room in shallow cans carefully position socket adapter and socket adjacent to the long side of the LED driver prior to inserting the retrofit trim into the can.(FIG.3)
4. Remove thermal protector used in the listed recessed luminaire if need.
(Also applicable to LED housing with connector)

FIG.2:Connect the terminals

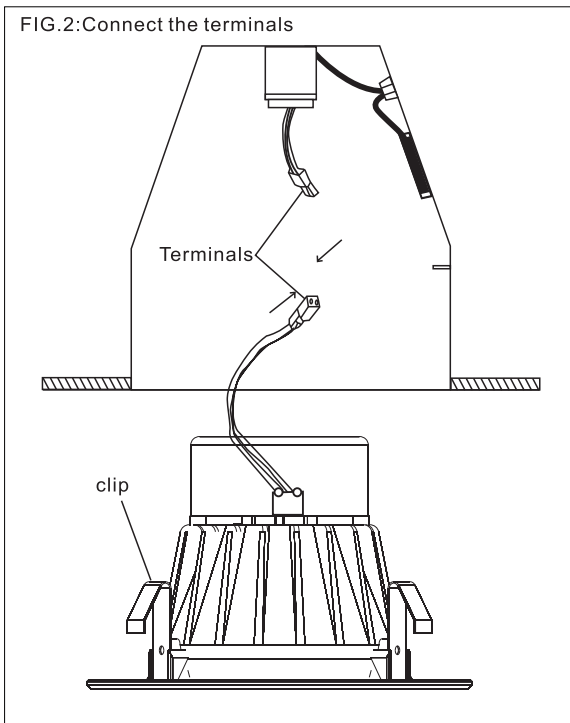

REPLACING LED LUMINAIRES:

- With fingertips,pull down firmly on trim ring until module stops.
- Take out the LED module directly ,and push the retrofit luminaire into can.
- Disconnect LED module wiring from recessed can (LED) Connector or screw in Edison base).

DIMMING:

The LED luminaire can be dimmed with many standard incandescent dimmers,however an electronic low voltage version of a standard dimmer low voltage version of a standard dimmer(with neutral connection) is recommended for many applications.Updates in dimmer technology on the dimmer type being used.To be assured of the latest information regarding luminaire and dimmer compatibility,please contact dimmer manufacturer.

ELECTRICAL CONNECTION:

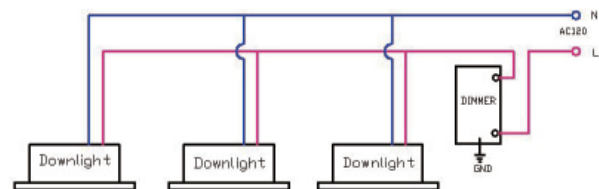
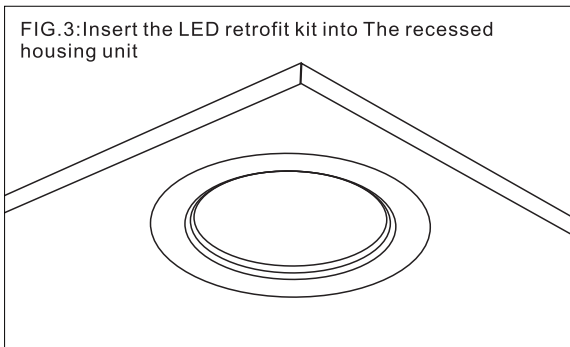

FIG.3:Insert the LED retrofit kit into The recessed housing unit



Warranty:

We offer 3 years limited warranty.As with any electrical installation,a qualified electrician must ensure compatibility of use with a particular housing;this includes all applicable national and local electrical and building codes.Installer is responsible to securely retain the LED Module in a housing at time of installation.