

## FIXTURE SPECIFICATIONS

### INTENDED USE

The specification grade **Lumo Cylinder Pendant** is designed with high color consistency and high lumen efficiency. The Lumo is ideal for use in dining areas, hallways, and work areas.

### FEATURES

- Construction:** Matte White Acrylic Solid Aluminum Cylinder
- Mounting:** Supplied with Universal Circular Strap for a Standard 4" J-Box or Plaster Ring
- 5 (CFL) Conductor Clear SJ Cord with a Standard Overall Hang Height of 24"
- Voltage:** 120-277V
- Wattage:** 10W
- Lumens:** 1200 lms
- Dimming:** 5-Wire 0-10V (100%-1%)
- CRI:** 80+
- Life:** 50,000 Hours
- Warranty:** 5 Years Limited Warranty for LED System
- Listings:** UL Listed
- Sound Rated A
- Suitable for Indoor and Damp Locations

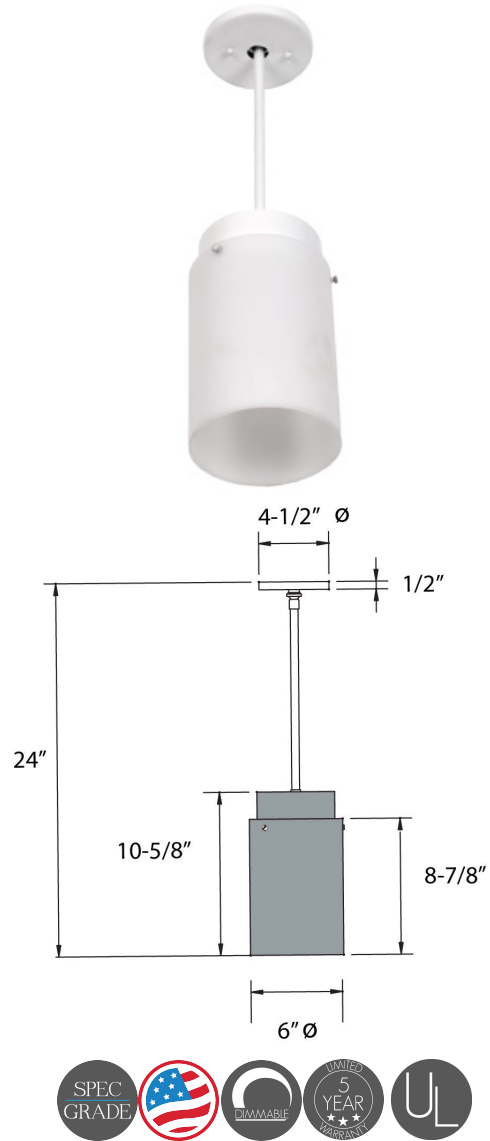

## ORDERING INFORMATION Example: (12320-27K-WH-REM)

Model	CCT	Finish	Options
<b>12320</b> Lumo	<b>27K</b> <b>30K</b> <b>35K</b> <b>40K</b>	<b>WH</b> Matte White <b>BK</b> Black	<b>REM</b> Remote Emergency Backup Battery