

FIXTURE SPECIFICATIONS

Project Name:

Type:

Quantity:

INTENDED USE

The 12250 is an architectural LED light pendant featuring a curved frosted acrylic tube twisted around a black finished center rod. The Alcon 12250 is ideal for energy efficiency, prolonged lifespan, and versatility bringing clean lines and clear light for an elegant lighting solution for any space.

FEATURES

- Construction:** Die-Cast Aluminum
- Lens:** Frosted Polycarbonate Lens
- Finish:** Black
- CRI:** 90+
- Wattage:** 27W
- Lumen:** 2358lm
- Color Temperature:** 3000K
- Voltage:** 120V
- Dimming:** 100%-10% Triac/ELV Dimming
- Lifetime:** 50,000 hours L70
- Listing:** cETLus, CA Title 24 JA8, Energy Star Compliant
- Warranty:** 5 Years Carefree for Parts & Components (Labor Not Included)

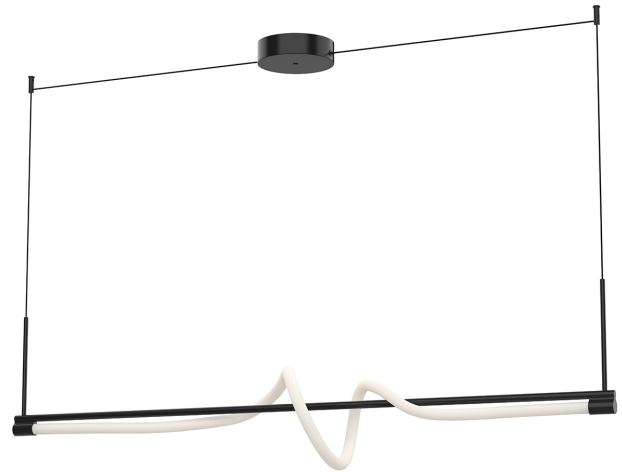

Center Canopy Mount

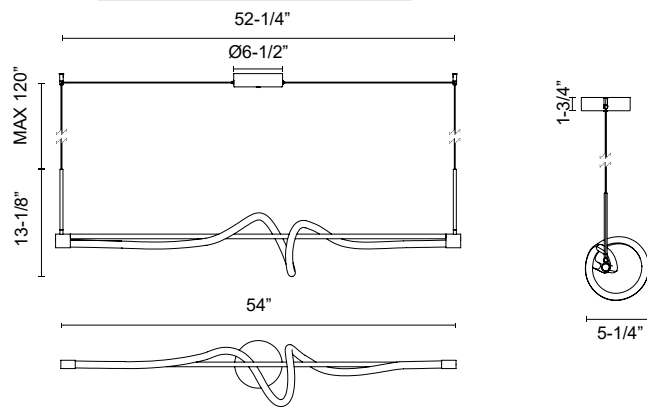

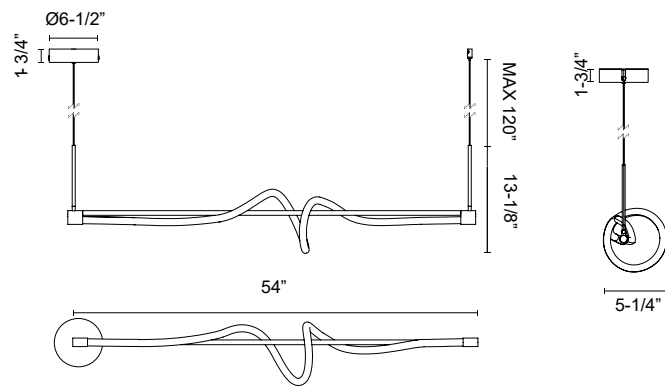

Side Canopy Mount



ORDERING INFORMATION Example: (12250-C)

Model	Canopy Mount
12250	C Center Canopy Mount S Side Canopy Mount

Alcon 12250 Architectural 54-Inch Curved Tube LED Pendant

	Triac	ELV
	DVCL-153P MALV-600 SCL-153P IPL06-10Z RRD-6NA	DVELV-300P DVELV-303P MAELV-600 SELV-300P SELVB-300-PR
		DSE06-10Z IPE04-1LZ VPE06-1LZ

COLOR TEMPERATURE GUIDE



2700K	3000K	3500K	4000K	5000K
WARM WHITE	SOFT WHITE GLOW	NEUTRAL GLOW	COOL WHITE GLOW	DAYLIGHT GLOW
friendly personal intimate	soft warm pleasing	sociable inviting non-threatening	neat clean efficient	bright cool alert
HOMES LIBRARIES RESTAURANTS	HOMES HOTEL ROOMS LOBBIES RETAIL STORES	EXECUTIVE OFFICES RECEPTION AREAS SUPERMARKETS	OFFICES CLASSROOMS MASS MERCHANTISERS SHOWROOMS	GRAPHICS INDUSTRY HOSPITALS GALLERIES BEAUTY SALONS
X	✓	X	X	X