

FEATURES & SPECIFICATIONS

INTENDED USE

The **Alcon Lighting Block Architectural LED Pendant Mount Direct Light Strip** features a compact design with efficient lighting that provides crisper brightness and more energy savings. The Block is ideal for indoor applications in industrial, commercial, institutional, or architectural installations.

DETAILS

**8 FT - W 2.75" x L 96" x H 3.625"**

**Construction:** Die-formed steel channel with knock-outs for versatile configuration and easy mounting  
Corrosion Resistant

**Finish:** High-gloss baked white enamel

**Lens:** Frosted Acrylic Diffuser

**Electrical:** Meets Class 1 or Class 2 Circuit

ADDITIONAL FEATURES

**Voltage:** 120-277 (50/60 Hz)

**Dimming:** 0-10V 1~100%

**CRI:** 83+

**Efficiency:** 126 lm/W

**Power Factor:** +0.95

**THD:** <20

**Operating Temperature:** -20°C (-4°F) - 50°C (122°F)

**Life:** L80 - 50,000 Hours

**Listings:** Suitable for Damp Locations

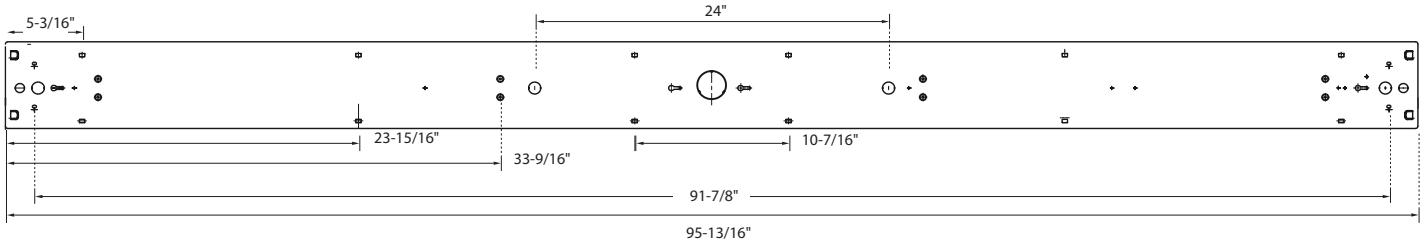
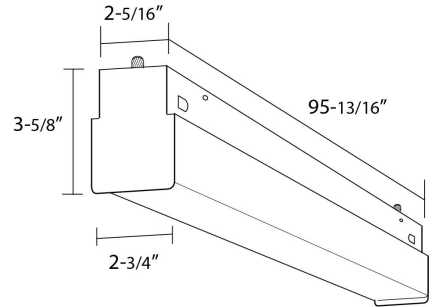

Ordering Information:

Example: (12171-8-54W-30K-AC48-EM5)

Model	Wattage and Lumens	Color Temp	Mounting	Options
<b>12171-8</b>	<b>54W</b> 54 watts / 5832 lms <b>72W</b> 72 watts / 7776 lms <b>108W</b> 108 watts / 11664 lms	<b>30K</b> 3000K <b>35K</b> 3500K <b>40K</b> 4000K <b>50K</b> 5000K	<b>AC48</b> 48" Adjustable Aircraft Cable (Standard) <b>AC96</b> 96" Adjustable Aircraft Cable <b>ST24</b> 24" Stem Mount Kit <b>ST48</b> 48" Stem Mount Kit	<b>EM5</b> 5W Emergency Ballast <b>EM8</b> 8W Emergency Ballast <b>EM16</b> 16W Emergency Ballast <b>DD</b> Integrated Daylight Dimming Photosensor <b>OS</b> Integrated Occupancy Sensor