

FEATURES & SPECIFICATIONS

INTENDED USE

The **Alcon Lighting Block Architectural LED Surface Mount Direct Light Strip** features a compact design with efficient lighting that provides crisper brightness and more energy savings. The Block is ideal for indoor applications in industrial, commercial, institutional, or architectural installations.

DETAILS

8 FT - W 2.75" x L 96" x H 3.625"

Construction: Die-formed steel channel with knock-outs for versatile configuration and easy mounting
Corrosion Resistant

Finish: High-gloss baked white enamel

Lens: Frosted Acrylic Diffuser

Electrical: Meets Class 1 or Class 2 Circuit

ADDITIONAL FEATURES

Voltage: 120-277 (50/60 Hz)

Dimming: 0-10V 1~100%

CRI: 83+

Efficiency: 126 lm/W

Power Factor: +0.95

THD: <20

Operating Temperature: -20°C (-4°F) - 50°C (122°F)

Life: L80 - 50,000 Hours

Listings: Suitable for Damp Locations

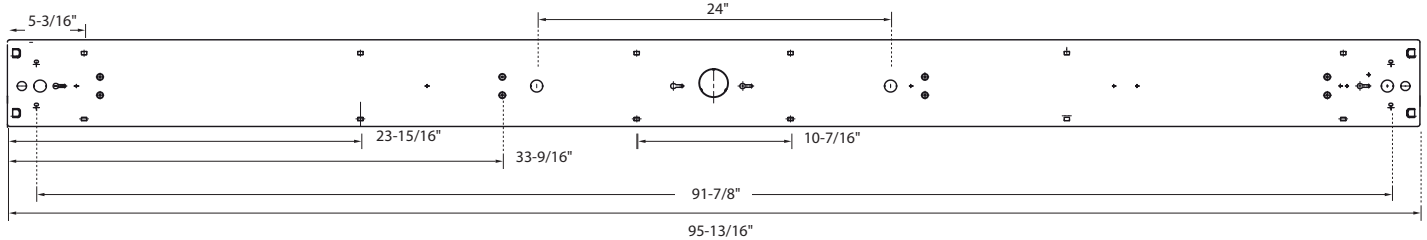
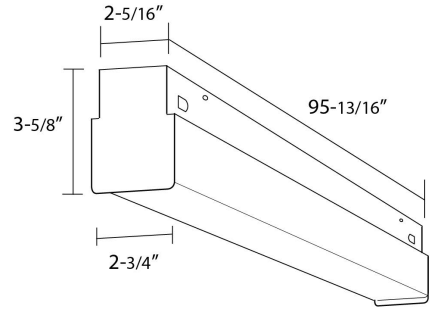

Ordering Information:

Example: (11243-8-54W-30K-AC48-EM5)

Model	Wattage and Lumens	Color Temp	Options
11243-8	54W 54 watts / 5832 lms	30K 3000K	EM5 5W Emergency Ballast
	72W 72 watts / 7776 lms	35K 3500K	EM8 8W Emergency Ballast
	108W 108 watts / 11664 lms	40K 4000K	EM16 16W Emergency Ballast
		50K 5000K	DD Integrated Daylight Dimming Photosensor
			OS Integrated Occupancy Sensor