

FIXTURE SPECIFICATIONS

INTENDED USE

The 5-Inch Architectural LED Outdoor Cylinder Surface Mount is designed for lasting durability and beauty while providing quality and energy efficient lighting for low to medium ceilings. The Exterior surface mount light is an ideal solution for clear and bright lighting in retail, hospitality, commercial, and high-end residential settings.

FEATURES

- Construction:** Die-Cast Aluminum
- Lens:** Frosted Polycarbonate Lens
- CRI:** 90+
- Wattage:** 19W
- Lumen:** 1600lm
- Voltage:** 120V
- Dimming:** 100%-10% Triac/ELV Dimming
- Lifetime:** 50,000 hours L70
- Listing:** cETLus, Suitable for Wet Location
- Warranty:** 5 Years Carefree for Parts & Components (Labor Not Included)

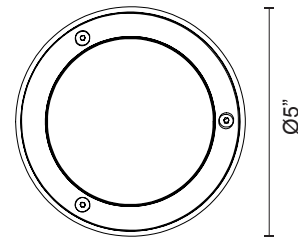
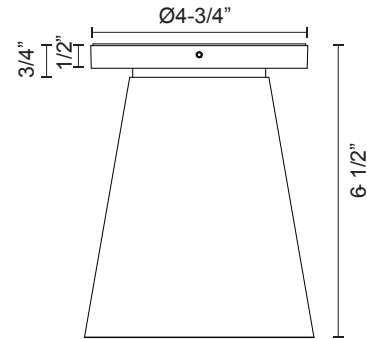

ORDERING INFORMATION Example: (11041-WH)

Model	Finish
11041	WH White
	BK Black

