



LED retrofit downlights are perfect for updating existing recessed lighting without changing the fixture. Replaces up to 70 Watt MH and 42 Watt CFL.

Color: White

Weight: 4.2 lbs

Project:

Type:

Prepared By:

Date:

Driver Info

Type: Constant Current
 120V: 0.25A
 208V: 0.15A
 240V: 0.13A
 277V: 0.12A
 Input Watts: 0W
 Efficiency: N/A

LED Info

Watts: 30W
 Color Temp: 4000K (Neutral)
 Color Accuracy: 82 CRI
 L70 Lifespan: 100000
 Lumens: N/A
 Efficacy: N/A

Technical Specifications

Listings

UL Listed:

Suitable for damp locations; non-IC-rated ceilings

IESNA LM-79 & LM-80 Testing:

RAB LED luminaires have been tested by an independent laboratory in accordance with IESNA LM-79 and LM-80, and have received the Department of Energy "Lighting Facts" label.

ENERGY STAR® V2.0:

This product is ENERGY STAR® V2.0 qualified.

Optical

Photometrics:

Photometrics are based on prorated reports. Contact the RAB Lighting Design department for the most up-to-date data.

Replacement:

The DLED8 30W replaces 50 Watt Metal Halide and 32 Watt CFL.

Electrical

Driver:

Class 2, Constant Current, 50-60Hz, 700mA

Universal Dimming Driver:

Universal dimming driver is compatible with TRIAC, ELV and 0-10V dimmers

Surge Protection:

6kV

Construction

Housing Component:

This component must be ordered with Retrofit Downlights Trim Module in order to make a complete fixture.

Lens:

Microprismatic diffusion lens for smooth and even light distribution

Mounting:

Ceiling clamps for easy installation into existing, commercial, recessed downlight frames with opening of 7 7/8" (200mm) minimum and 8 7/8" (225.4mm) maximum (ceiling+can/pan thickness 1 7/16" maximum).

Compatibility:

Low-profile design for maximum compatibility with 8" incandescent recessed downlight housings.

Housing:

Formed galvanized steel construction

Heat Sink:

Die-cast aluminum with external fins for maximum heat dissipation

Finish:

Our environmentally friendly polyester powder coatings are formulated for high-durability and long-lasting color, and contains no VOC or toxic heavy metals.

Green Technology:

Mercury and UV free, and RoHS compliant.

LED Characteristics

Lifespan:

100,000-hour LED lifespan based on IES LM-80 results and TM-21 calculations.

LEDs:

Long-life, high-efficiency surface mount LEDs with 3 step binning

Color Consistency:

3-step MacAdam Ellipse binning to achieve consistent fixture-to-fixture color.

Other

Warranty:

RAB warrants that our LED products will be free from defects in materials and workmanship for a period of ten (10) years from the date of delivery to the end user, including coverage of light output, color stability, driver performance and fixture finish.

DLED8R30N

Dimensions

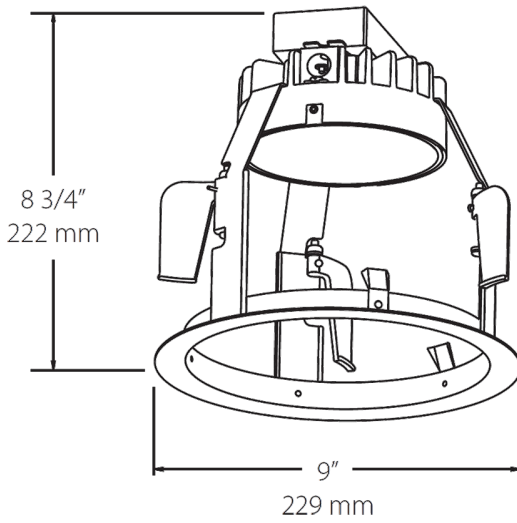

Features

- Universal driver is compatible with TRIAC, ELV and 0-10V dimmers
- Lightweight design for easy installation and increased safety
- 100,000-Hour LED lifespan
- 10 year warranty

Ordering Matrix

Family	Size	Shape	Watts	Color Temp	CRI
DLED	8	R	30	N	^
	8 = 8"	R = Round	30 = 30W 38 = 38W	YY = 2700K (Residential Warm) Y = 3000K (Warm) YN = 3500K (Warm Neutral)	= 82 CRI HC = 94 CRI