

# Assembly & Installation Instructions

Planar Pendant Small LED 139718D

**A398**

Page 1 of 2

**CAUTION:** FAILURE TO INSTALL THIS FIXTURE PROPERLY MAY RESULT IN SERIOUS PERSONAL INJURY OR DEATH AND PROPERTY DAMAGE. We recommend installation by a licensed electrician.

This product must be installed in accordance with applicable installation code(s), by a person familiar with the construction and operation of the product and the hazards involved.\*

**Caution:** Do not exceed maximum wattage noted on fixture. Use only recommended bulbs with fixture.

**Please Note:** After installation extra hardware and accessories are possible due to our kits are used on multiple products and options.

## Stem Assembly (Figure 1)

### Component Parts

- A Fixture Pipe
- B Fixture Coupling

1. Carefully unpack the fixture from the carton.
2. Carefully slip fixture pipe (A), over fixture wires.
3. Apply a drop of the supplied thread-locking compound to the threads of fixture pipe (A) and screw pipe into fixture coupling (B), being careful not to twist or pinch the wires.

**Note:** Application of the thread locking compound is necessary to prevent the stem from loosening during regular maintenance and cleaning of the fixture. Be certain to apply the compound.

4. See instructions below to complete the installation.

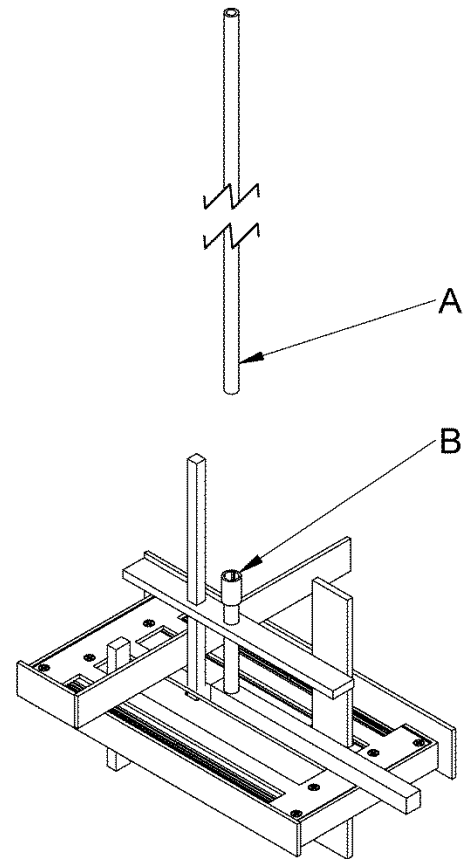

(Figure 1)

# Assembly & Installation Instructions

Planar Pendant Small LED 139718D

**A398**

Page 2 of 2

(continued)

## Complete Assembly and Install Fixture (Figure 2 & 3)

### Component Parts

A	Fixture Pipe	F	Canopy	J	Clutch
C	Crossbar	G	Barrel Nuts (2)	K	Set Screw
D	Ground Screw	H	Canopy Pipe	L	#8 Screw
E	Threaded Studs (2)	I	Plastic Sleeve	M	Cable

### Caution: Be sure power is off at the main breaker box prior to installation

1. Thread studs (E) through appropriate holes in cross bar (C) to match hole centers in canopy (F). Move ground screw (D) to another available threaded hole if necessary.
2. Using two machine screws (not provided) fasten crossbar (C) to electric box.  
**Note:** A new electric box comes with screws. When replacing an existing fixture, retain the screws for use with the new fixture.
3. Slip wires from the fixture pipe (A) through the canopy pipe (H).
4. Unscrew the clutch (J) from the canopy pipe (H); slide it across the wires and onto the fixture pipe (A). Follow this with the plastic sleeve (I), oriented so the tapered end nests in the clutch (J) (Figure 3).
5. Slide the canopy pipe (H) as far as necessary to give total desired length of the fixture. Be careful not to scratch the pipe surfaces and to pull excess wire up through the canopy pipe (H). There must be a minimum 1-1/2" of inner pipe inside the outer pipe. Hand-tighten the clutch to temporarily hold this adjustment. The clutch (J) is not securely fastened at this point; do not depend on it to hold the fixture.

**Important:** To ensure full connection strength, be sure the tapered end of the plastic clutch sleeve is oriented toward the clutch when assembled and securely tighten set screw (Figure 3).

6. Attach cable (M) to crossbar (C) with #8-32 screw (L).
7. Black and red wires on driver are shipped with connectors attached. Lift one of the Empty orange levers in the connector up, to accept the wire. Verify the blue and red wires coming from the fixture are stripped (if not please strip them 1/4 inch). Connect wires from fixture to connectors on driver, red to red and blue to black.
8. Using suitable wire connectors (not provided), connect fixture wires to supply wires (white to white and black to black). Run a pigtail lead from crossbar ground screw (D) toward the junction box. Using suitable wire connector (not provided) connect fixture ground wire and pigtail lead to ground wire(s) from electrical box (bare copper or green to bare copper or green). **Caution:** Make sure wire connectors are twisted on securely, and no bare wire is exposed.
9. Slide fixture canopy (F) over threaded studs (E) and push firmly to ceiling, making sure that no wires are pinched between fixture canopy (F) and ceiling. Fasten with barrel nuts (G).
10. Once the fixture is fastened to the ceiling, tighten the set screw (K) firmly with hex wrench provided.
11. Restore electricity at main breaker.

If you need further assistance, or find that you are missing any parts, please contact the dealer from which you purchased this product. We hope you enjoy your fixture.

Hubbardton Forge will not be liable for injury or damage caused by improper installation, lamping or use of this fixture.

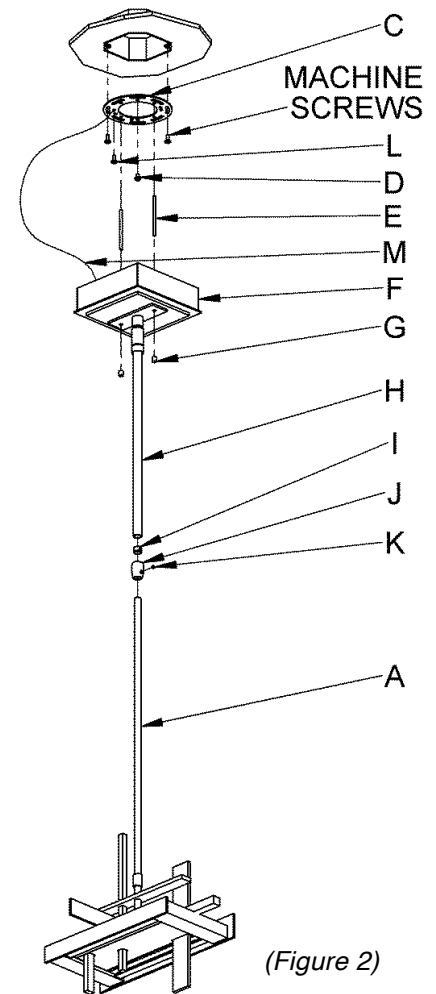

(Figure 2)

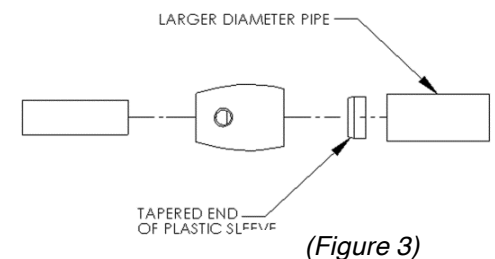

(Figure 3)