

### Warning:

- Caution - Risk of Shock. This product must be installed in accordance with the applicable installation code by a person familiar with the construction and operation of the product and the hazards involved.
- Make sure all electrical power is turned off while installing the fixture.
- Warning Risk of Electrical Shock - Verify that supply voltage is correct by comparing it with the luminaire label information.
- This luminaire must be adequately grounded for protection against shock hazards and to assure proper operation.
- Disconnect power before servicing.
- Always use correct lamp type and wattages.
- Suspend from adequate structure that can safely support the fixture.

### LED Handling Warning:

- LEDs are ESD (Electro Static Discharge) sensitive devices that can be easily damaged if the proper ESD mitigating steps are not taken.
- LEDs are very sensitive to mechanical damage. Caution must be taken to avoid damage to the LEDs.
- ESD or mechanical damage voids all warranties.

## STAND-ALONE ASSEMBLY

**Step 1:** T-bar mounting bracket halves are supplied as a one-piece metal stamping. Break mounting bracket apart. Insert 1/4-20 threaded stud into "A" half of bracket (Fig. 1).

**Step 2:** For T-bar ceiling, install mounting brackets at desired locations. Brackets must be placed exactly on each mounting point for correct installation and hanging of cables.

**Step 2:** T-bar mounting bracket halves interlock. Snap side "B" together with side "A" around T-bar. (Fig. 2).

**Step 3:** Suspension locations must be securely supported to the structure before hanging light fixtures onto brackets. Use 12-gauge or stronger steel ceiling support wire (Fig. 3).

**Step 4:** Place the canopy flush to ceiling tile and thread upper cable retainer onto the 1/4 - 20 stud (Fig. 3).

A stand-alone fixture will require two suspension cables. The 5" diameter canopy will be used only at power feed locations. Smaller 2" canopies are to be used at non-feed locations (Fig. 4). Power feed cord will pass through hole with plastic strain relief bushing.

**Note:** For safety, always support the weight of the fixture. Do not leave a fixture hanging by only one end while working.

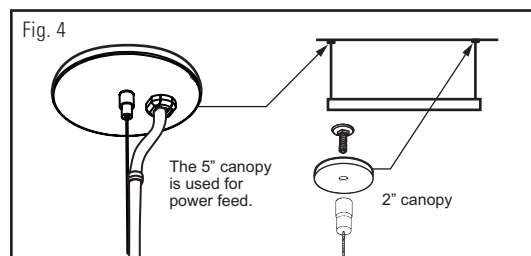
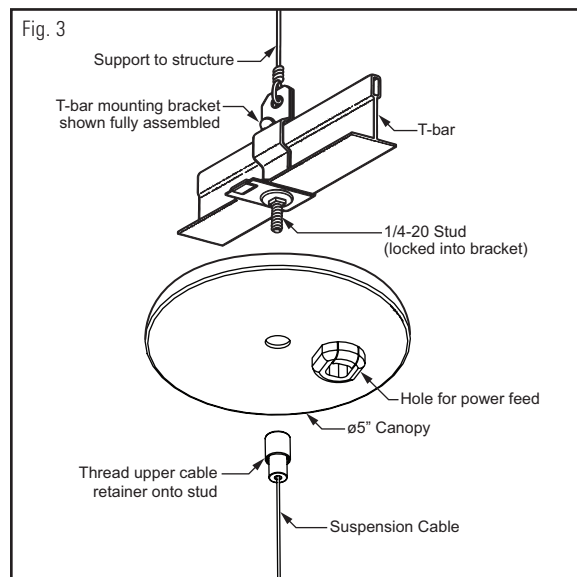
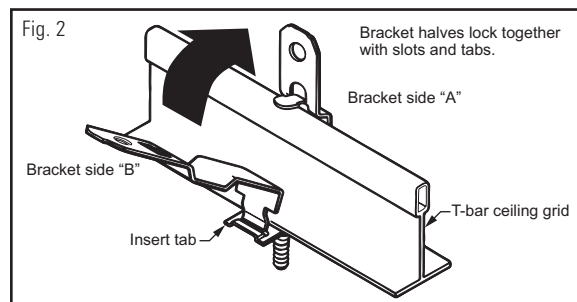
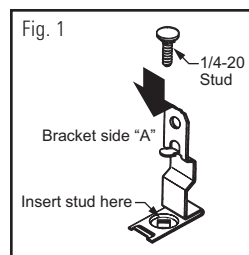

# AXA SERIES INSTALLATION INSTRUCTIONS

## MOUNTING POINT DIMENSIONS

Stand alone fixture

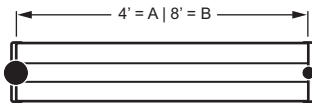

- 5" canopy power feed
- 2" canopy non-power

Light Source	Maximum Mounting Length			
	4' Fixture (A)	8' Fixture (B)	4' Fixture (C)	8' Fixture (D)
T5/LED	45"	90-15/16"	46-15/16"	92-15/16"
T8	47"	94-15/16"	48-15/16"	96-15/16"

Continuous row

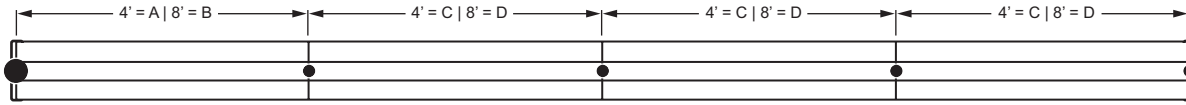

## ATTACH FIXTURE

**Step 1:** Once mounting hardware is installed, locate extrusions and attach by applying pressure to the mounting clip and snapping it over the top of the extrusion.

To snap on, hook mounting clip on one side of extrusion, then rock clip over and snap on the other side (Fig. 5).

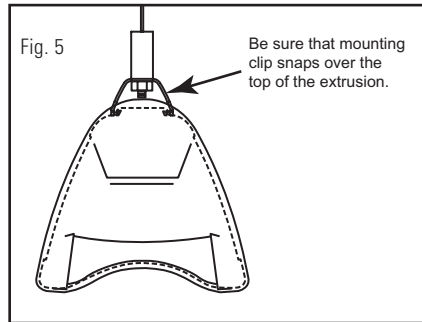

**Step 2:** Hang the fixture from suspension cables by hooking into each end of light fixture. Install 10-32 flange nuts from the hardware kit onto threaded cable end (Fig. 5) and adjust up or down as necessary until fixture is level (Fig. 6).

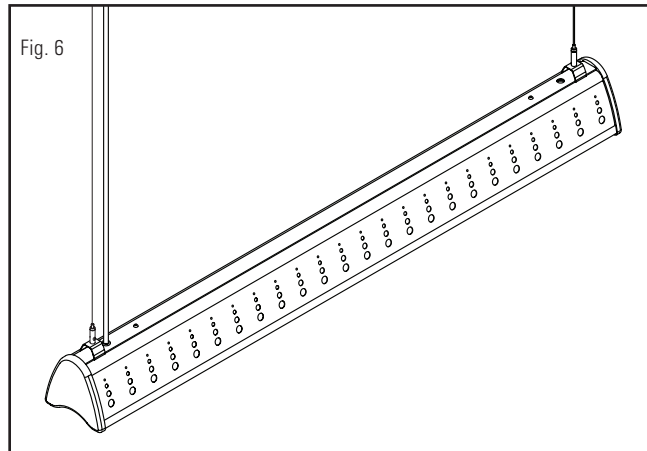

# AXA SERIES INSTALLATION INSTRUCTIONS

## DETAIL OF T-BAR MOUNTED J-BOX FOR POWER FEED

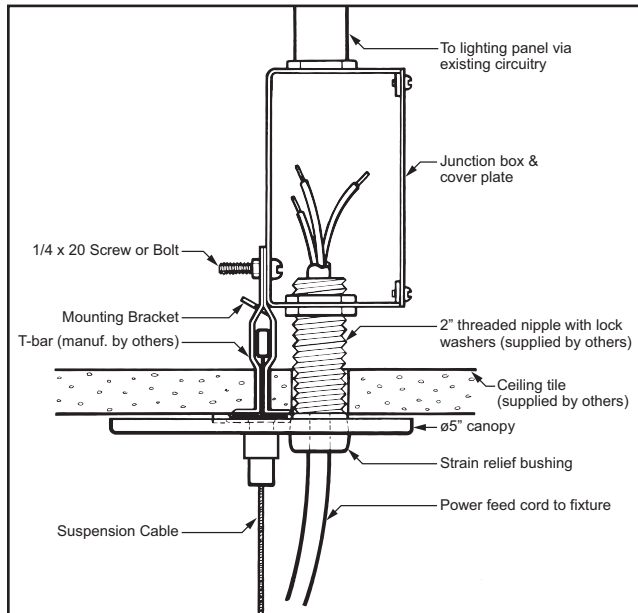

## ROW MOUNTING

**Note:** Only the first fixture in each row will require two suspension cables. Each adjoining fixture will require only one cable before attaching to the previous fixture.

Begin each row by hanging and leveling the power feed fixture from the following suspension cable and attach to the end of the first fixture as follows:

**Step 1:** Plug fixtures together with quick-connect wiring at fixture ends.

**Step 2:** Insert three #8 screws, included with joiner fixture hardware kit, through holes in end plates and cast row aligner to securely fasten fixtures together.

Each additional fixture in the row attaches in the same manner.

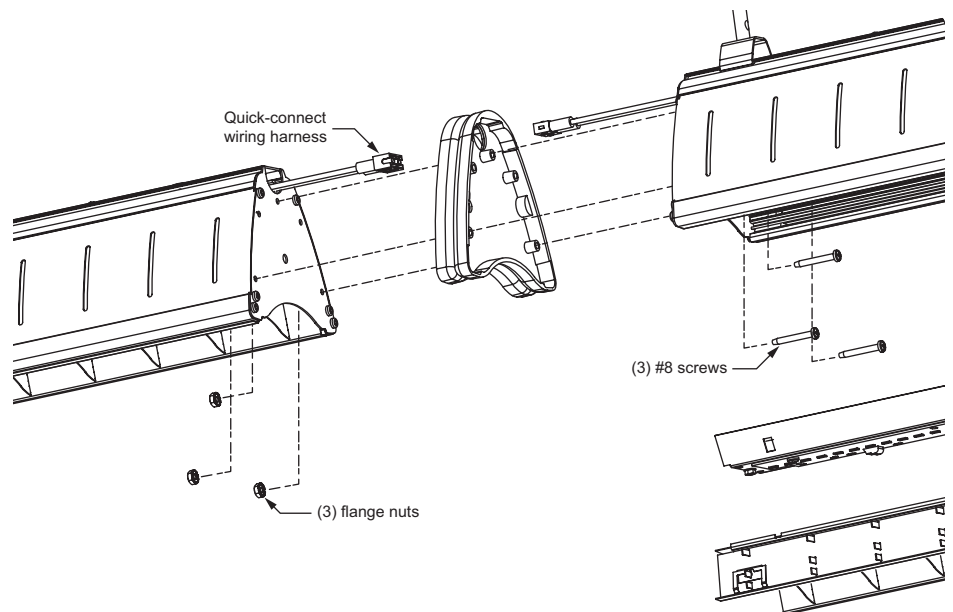

### Power Feed Hardware:

Each power feed hardware kit includes the following:

- (1) Assembly & Installation Instructions
- (2) T-bar mounting brackets & 1/4 - 20 studs
- (1) 5" diameter canopy with retaining screw
- (1) 2" diameter canopy
- (2) Suspension cables with hardware
- (3) Flange nuts with serrations
- (1) Strain relief bushing
- (5) Cable ties (white plastic)

### Joiner/End Fixture Hardware:

Each non-power feed hardware kit includes the following:

- (1) T-bar mounting bracket & 1/4 - 20 stud
- (1) 2" diameter canopy with 1/4" diameter
- (1) Suspension cable with hardware
- (1) 10 - 32 flange nut with serrations
- (3) #8 screws