

KR4™ Series

LED Specification Downlight – Round 4" Aperture

Product Description

The KR4™ LED specification downlight features Cree TrueWhite® Technology and delivers beautiful, high-quality light with efficacy up to 75 lumens per watt. Designed for new construction applications, the KR Series is available in variety of color temperatures, round and square trims with high-quality anodized aluminum reflector finishes, a sloped ceiling adapter and a variety of dimming options including Cree Sunset Dimming Technology providing rich, warm light that transitions from 2700K to 1800K as naturally as an incandescent source.

Performance Summary

Utilizes Cree TrueWhite® Technology
Made in the U.S.A. of U.S. and imported parts
Delivered Light Output: 665-3199 lumens; Delivered lumen output is typical when using a SSGC type reflector
Input Power: 13-44 Watts
Emergency Performance: Up to 1210 Lumens; 10W; Minimum 90 Minutes
CRI: 90
CCT: 2700K, 3000K, 3500K, 4000K
Dimming: Triac, 0/1-10V, Cree SmartCast™ Technology, Lutron EcoSystem® Dimming, Lutron® Forward Phase Dimming; See control availability chart on page 3
Limited Warranty*: 10 years on KR4™ luminaire/5 years on KR4™ luminaire with Cree SmartCast™ Technology/1 year on emergency battery pack

Field-Installed		
Sloped Ceiling Adaptor KRKS4+WW ** 0-35 (order in 5 degree increments)	C-Channel Hanger Bars RBH30C - Pair of 30" (762mm) rigid 3/4" x 1/2" (19mm x 13mm) C-Channel bars	T-Bar Clips RARC7 - Set of four
Control Module CIF-10VC1-CWC-SNSR - Cree SmartCast™ Technology with ambient light and motion sensors		Trim Ring KR4TA - White

Ordering Information

Fully assembled luminaire is composed of two components that must be ordered separately:
Example: **Housing:** KR4 20L 35K 120V 10V + **Reflector:** KR4T SSGC FF

Reflector (Housing must be ordered separately)		
KR4T		
Series	Reflector Finish	Flange Finish
KR4T	SSGC Soft Satin Glow, Clear SSGCG Soft Satin Glow, Champagne Gold	FF Matches Reflector WF White Paint

Housing (Reflector must be ordered separately)									
Series	Size	Reflector	Initial Delivered Lumens	Optic	CCT	Voltage	Controls	Options	
KR	4 inch	Blank Round	9L 13W, 665 Lumens - 51 LPW 13L 18W, 977 Lumens - 54 LPW 20L 30W, 1546 Lumens - 52 LPW 30L 39W, 2348 Lumens - 60 LPW 40L 44W, 3199 Lumens - 73 LPW	Blank 70° Beam Angle (Standard)	27K 2700K - 9L thru 40L Only 30K 3000K 35K 3500K 40K 4000K	120V 120 Volts 277V 277 Volts 347V 347 Volts	Blank - For standard control offering refer to control availability chart on page 3 LES Lutron EcoSystem® Dimming - Refer to control availability chart on page 3	10V 0/1-10V Dimming - Refer to control availability chart on page 3 LFP Lutron Forward Phase Dimming - Refer to control availability chart on page 3	WD Sunset Dim - 9L and 13L @ 27K with Triac Dimming only 10R Cree SmartCast™ Technology** EB7+ Emergency Backup - Minimum 90 minutes - 120V, 277V only

* See www.cree.com/lighting/products/warranty for warranty terms
• Available for U.S. only.
** Not available in 40L and 60L

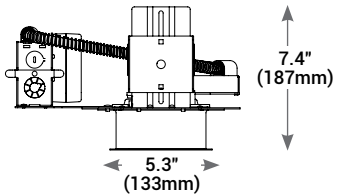
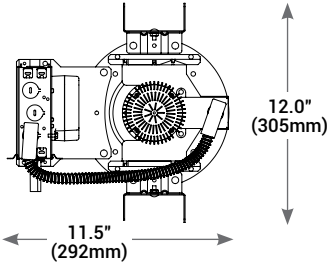

Emergency Backup

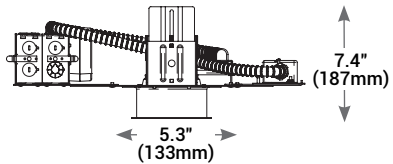
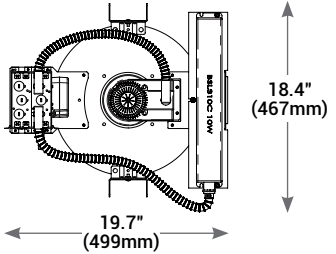

Rev. Date: V6 09/25/2014



KR4™ Series - Round 4" Aperture

Product Specifications

CREE SMARTCAST™ TECHNOLOGY

Cree SmartCast™ Technology changes the paradigm of lighting control. With the press of a single button, Cree SmartCast™ Technology enabled luminaires and controls create their own secure network and auto-associate to form logical groups throughout every space. Integrated sensors and robust wireless communication included in every luminaire combined with revolutionary OneButton™ Setup enables automated setup and configuration of luminaires and wall controls. With no extra wires or interfaces, Cree SmartCast™ Technology products reduce installation time and complexity.

CREE TRUEWHITE® TECHNOLOGY

A revolutionary way to generate high-quality white light, Cree TrueWhite® Technology is a patented approach that delivers an exclusive combination of 90+ CRI, beautiful light characteristics, and lifelong color consistency, all while maintaining high luminous efficacy – a true no compromise solution.

CONSTRUCTION & MATERIAL

- Initial color within a 3-step MacAdam Ellipse
- Low brightness parabolic spun Alzak aluminum cone, 0.06" (2mm) thick with polished radius and continuous self-flange
- Soft Satin Glow Clear finish, standard
- 2" (51mm) aperture throat to accommodate all standard and up to 3" (76mm) thick ceilings and provide flexibility in mounting within grid
- Provided with quick mounting brackets for optional carrying channels
- Light engine, optics, and driver accessible from below ceiling

ELECTRICAL SYSTEM

- **Power Factor:** > 0.9 for 120V and 277V
- **Input Power:** 120, 277V, or 347V, 50/60Hz

REGULATORY & VOLUNTARY QUALIFICATIONS

- cULus Listed
- Suitable for thru-wiring 8#12AWG-90°C
- Suitable for damp locations
- Thermally protected Type NON-IC in accordance with Article 410 of the NEC and UL 1598
- Meets Buy American requirements within ARRA
- EnergyStar® Qualified. Please refer to <http://www.energystar.gov> for most current information

Recommended Cree® KR Series Lumen Maintenance Factors (LMF) ¹						
Ambient	Initial Delivered Lumens	Initial LMF	25K hr Projected ² LMF	50K hr Projected ² LMF	75K hr Calculated ³ LMF	100K hr Calculated ³ LMF
5°C (41°F)	9L and 13L	1.05	1.04	1.03	1.03	1.02
	20L and 30L	1.03	0.99	0.94	0.90	0.86
	40L	1.03	0.96	0.90	0.83	0.77
10°C (50°F)	9L and 13L	1.04	1.03	1.03	1.02	1.02
	20L and 30L	1.02	0.97	0.93	0.89	0.85
	40L	1.03	0.95	0.88	0.82	0.76
15°C (59°F)	9L and 13L	1.03	1.02	1.02	1.01	1.01
	20L and 30L	1.01	0.96	0.91	0.88	0.84
	40L	1.02	0.94	0.87	0.81	0.75
20°C (68°F)	9L and 13L	1.02	1.01	1.00	1.00	0.99
	20L and 30L	1.01	0.95	0.90	0.87	0.83
	40L	1.01	0.93	0.86	0.80	0.74
25°C (77°F)	9L and 13L	1.00	1.00	0.99	0.99	0.99
	20L and 30L	1.00	0.94	0.89	0.86	0.82
	40L	1.00	0.92	0.85	0.79	0.74
30°C (86°F)	9L and 13L	0.99	0.99	0.98	0.98	0.98
	20L and 30L	0.97	0.93	0.88	0.85	0.81
	40L	0.98	0.91	0.84	0.78	0.73
35°C (95°F)	9L and 13L	0.98	0.97	0.97	0.97	0.97
	20L and 30L	0.96	0.92	0.87	0.84	0.80
	40L	0.96	0.90	0.83	0.77	0.72

¹ Lumen maintenance values at 25°C (77°F) are calculated per TM-21 based on LM-80 data and in-situ luminaire testing

² In accordance with IESNA TM-21-11, Projected Values represent interpolated value based on time durations that are within six times (6X) the IESNA LM-80-08 total test duration (in hours) for the device under testing (DUT) i.e. the packaged LED chip

³ In accordance with IESNA TM-21-11, Calculated Values represent time durations that exceed six times (6X) the IESNA LM-80-08 total test duration (in hours) for the device under testing (DUT) i.e. the packaged LED chip

Installation

- Recommended ceiling cutout 4.25" (108mm)



Note: 30L versions require marked spacing: 24" (600mm) X 12" (300mm) X ½" (12mm). 24" (600mm) luminaire to luminaire, 12" (300mm) luminaire to side wall, ½" (12mm) above luminaire

60L versions require marked spacing: 48" (1219mm) X 24" (600mm) X 1" (25mm). 48" (1219mm) luminaire to luminaire, 24" (600mm) luminaire to side wall, 1" (25mm) above luminaire

Cree SmartCast™ Technology

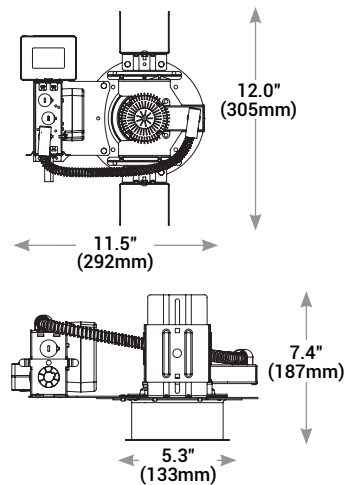

Emergency Backup and Cree SmartCast™ Technology

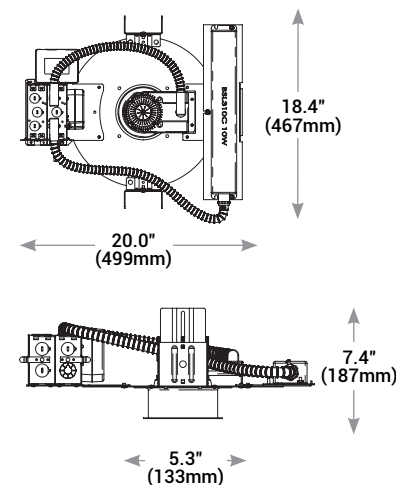

Occupancy Sensor included with Cree SmartCast™ Technology

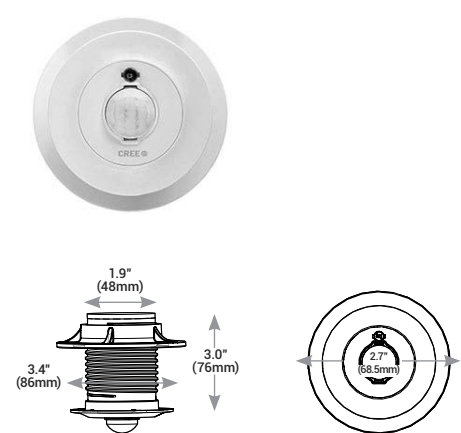

KR4™ Series - Round 4" Aperture

Photometry

KR4 30L 27K 120V W/KR4T SSGC WF BASED ON UL REPORT TEST #: 157461

Fixture photometry has been conducted in accordance with IESNA LM-79-08. IESNA LM-79-08 specifies the entire luminaire as the source resulting in a fixture efficiency of 100%.

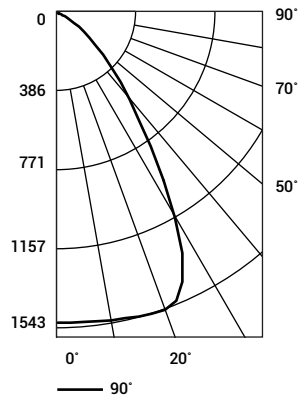

UL Test Report #: 157461
 KR4 30L 27K 120V SSGC FF
 Initial Delivered Lumens: 2235
 Efficacy: 59.0 LPW
 S/M: 1.16

Coefficients Of Utilization – Zonal Cavity Method				
RC %:	80			
RW %:	70	50	30	10
RCR: 0	119	119	119	119
1	112	109	106	104
2	106	100	95	91
3	99	91	86	81
4	93	84	77	73
5	87	77	71	66
6	82	72	65	60
7	77	66	59	54
8	73	62	55	50
9	69	58	51	46
10	65	54	47	43

Effective Floor Cavity Reflectance: 20%

Average Luminance Table (cd/m2)			
Vertical Angle	Horizontal Angle		
	0°	45°	90°
45°	59,182	59,182	59,182
55°	30,926	30,926	30,926
65°	12,854	12,854	12,854
75°	6,046	6,046	6,046
85°	1,795	1,795	1,795

Zonal Lumen Summary			
Zone	Lumens	% Lamp	Luminaire
0-30	1,228	N/A	54.8%
0-40	1,733	N/A	77.4%
0-60	2,170	N/A	96.9%
0-90	2,239	N/A	100.0%
0-180	2,239	N/A	100.0%

Cone of Light		
Distance from Workplane	Footcandles	Beam Diameter
6' (1.8m)	42	6.9' (2.1m)
8' (2.4m)	24	9.1' (2.8m)
10' (3.0m)	15	11.5' (3.5m)
12' (3.7m)	11	13.5' (4.1m)
14' (4.3m)	8	15.8' (4.8m)

For exact photometric data, please reference our available IES and LM-79 test results at <http://www.cree.com/Lighting/Products/Indoor/Architectural-Downlights/KR-Series>

Application Reference

Based on KR4 30L 27K 120V W/KR4T SSGC FF Luminaire

Open Space					
Spacing	Lumens	Wattage	LPW	w/ft²	Average FC
4 x 4	2348	39	60	2.34	137
6 x 6				1.09	65
8 x 8				0.59	36
10 x 10				0.39	26

10' Ceiling, 80/50/20 Reflectances, 2.5 workplane. LLF: 1.0 Initial. Open Space: 50' x 40' x 10'

Corridor					
Spacing	Lumens	Wattage	LPW	w/ft²	Average FC
4' on Center	2348	39	60	1.63	69
6' on Center				1.11	47
8' on Center				0.78	34
10' on Center				0.65	28

10' Ceiling, 80/20/50 Reflectances, Light levels on the ground. LLF: 1.0 Initial. Corridor: 6' Wide x 100' Long

Control Availability Chart

Initial Delivered Lumens	Non Dimming			Triac Dimming to 5%			0/1-10V Dimming to 10%			LES Dimming to 1%			LFP Dimming to 1%		
	120V	277V	347V	120V	277V	347V	120V	277V	347V	120V	277V	347V	120V	277V	347V
9L	N/A	S	N/A	S	N/A	N/A	0	0	0	N/A	N/A	0	N/A	N/A	N/A
13L	N/A	S	N/A	S	N/A	N/A	0	0	0	0	0	0	0	N/A	N/A
20L	N/A	N/A	N/A	N/A	N/A	N/A	S	S	S	0	0	0	0	N/A	N/A
30L	N/A	N/A	N/A	N/A	N/A	N/A	S	S	S	0	0	0	0	N/A	N/A
40L	N/A	N/A	N/A	N/A	N/A	N/A	S	S	S	0	0	0	N/A	N/A	N/A
60L	N/A	N/A	N/A	N/A	N/A	N/A	S	S	S	0	0	0	N/A	N/A	N/A

S = Standard Offering
 0 = Optional Offering

© 2014 Cree, Inc. All rights reserved. For informational purposes only. Content is subject to change. See www.cree.com/patents for patents that cover these products. Cree®, the Cree logo, Cree TrueWhite®, TrueWhite®, and the Cree TrueWhite Technology logo are registered trademarks, and KR4™ and the Quick Ship logo are trademarks of Cree, Inc. Lutron® and EcoSystem® are registered trademarks of Lutron, Inc. The UL logo is a registered trademark of UL LLC. ENERGY STAR® and the ENERGY STAR logo are registered trademarks of the United States Environmental Protection Agency.

US: www.cree.com/lighting

T (800) 236-6800 F (262) 504-5415

Canada: www.cree.com/canada

T (800) 473-1234 F (800) 890-7507

