

## DESCRIPTION

The Corelite R mini combines the lumen package and convenience of a down-light with the volumetric distribution that characterizes the Class R family. The proprietary low-power LED platform developed by Cooper Lighting delivers a soft, diffuse volume of pure white light that carries the general character of a fluorescent source. Simultaneously, the ALM module eliminates unsightly socket shadows and the constant hassle of luminaire maintenance. The R mini can be installed in a standard grid ceiling or most concealed ceiling applications and is available in both CFL and LED. The R mini offers countless solutions for the most demanding energy requirements.

## SPECIFICATION FEATURES

### A ... Construction

Low profile housing constructed of die formed 20 gauge cold rolled steel with integral 20 gauge gear tray.

### B ... Reflector

Precision tooled, high reflectance sheet metal which allows for easy access to driver compartment from below ceiling plenum.

### C ... Shielding

High light transmission clear acrylic outer lens contains acrylic frosted sheet inlay with perf pattern. Each component contains UV inhibitors. The lens assembly minimizes lamp image and ensures efficient light distribution. Lenses secured to housing via injection molded inserts for easy lamp access.

### D ... Electrical

Fixture equipped with proprietary Cooper LED modules available in 3000, 3500 or 4000k with a CRI plus or minus 85. Removable module features aluminum extrusion providing exceptional thermal management. Modules are driven using universal voltage switch mode LED drivers. Fixture and modules certified to UL and CUL standards. A 0 to 10V dimming control is available.

### E ... Finish

Fixture housings are high reflectance white using electrostatically applied polyester powder coat paint.

### Mounting

Fixture available in two mounting options. CC allows for fixture to be installed into inaccessible ceilings (sheet rock, wood panel, etc.). Compression bracket provided. G1 allows for fixture to be installed in standard ceiling tile. Butterfly brackets supplied mount to cross-braces (by others).

Catalog #		Type
Project		
Comments		Date
Prepared by		

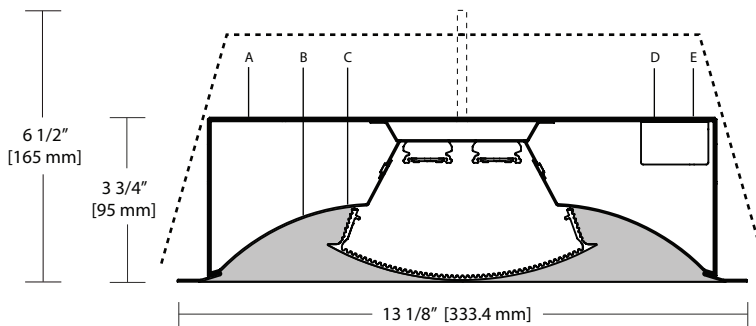
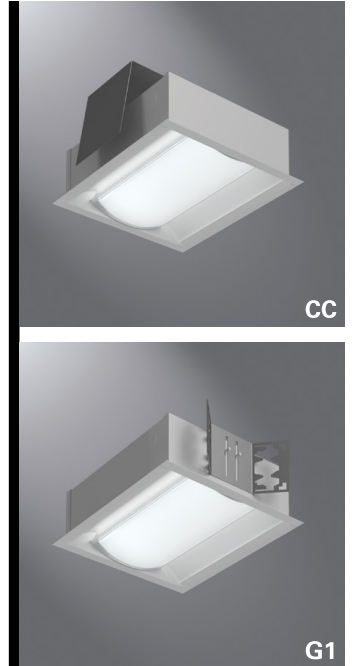

**R MINI**  
Rectangular Perf Inlay  
Round Perf Inlay

LED  
**1'x1' Recessed**  
3-3/4" Depth

## ORDERING INFORMATION

Sample Number: RM-WG-2L30-1C-UNV-11-G1

<b>Series</b> RM: Class RM	<b>Shielding</b> D: Round Perf Inlay G: Rectangular Perf Inlay	<b>Color Temperature</b> L30: LED 3000K L35: LED 3500K L40: LED 4000K	<b>Wiring</b> <sup>1</sup> B: Battery Pack C: Standard Circuit D: Dimming E: Emergency T: Nightlight Y: Daylight	<b>Voltage</b> <sup>1</sup> 120: 120V 277: 277V 347: 347V UNV: Universal (120V-277V)	<b>Ceiling Type</b> CC: Concealed Ceiling G1: Grid Ceiling	<b>Options</b> <sup>1</sup> CP: Chicago Plenum NY: New York City Construction W6: 6' Whip Flex W12: 12' Whip Flex
<b>Reflector</b> W: White	<b>Light Level</b> 2: Light Level 2	<b>Number of Circuits</b> 1: 1 Circuit		<b>Size</b> 11: 1' x 1'		

Notes: 1 Not all options available. Please consult your Cooper Lighting Representative for availability. Specifications and dimensions subject to change without notice.

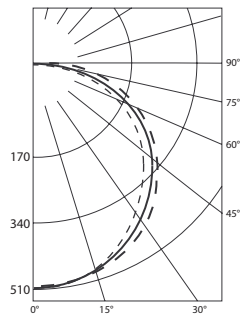

RM-WD-2L35-1x1  
1338 Lumens  
19.4 Watts  
69.0 LPW  
LED ALM 2.0

Test Report: #P22414

**Coefficients of Utilization**

rc	Effective floor cavity reflectance 20%																				
	80%				70%				50%				30%				10%				0%
	rw	70	50	30	10	70	50	30	10	50	30	10	50	30	10	50	30	10	0		
RCR	0	119	119	119	119	116	116	116	116	111	111	111	106	106	106	102	102	102	100		
	1	109	104	100	96	106	102	98	95	98	94	92	94	91	89	90	88	86	84		
	2	99	91	84	78	96	89	83	77	85	80	76	82	78	74	79	76	72	70		
	3	90	80	72	65	88	78	71	65	75	69	64	73	67	62	70	65	61	59		
	4	83	71	62	55	80	69	61	55	67	60	54	65	58	53	62	57	53	51		
	5	76	63	54	48	74	62	54	47	60	53	47	58	52	46	56	50	46	44		
	6	70	57	48	42	68	56	48	41	54	47	41	53	46	41	51	45	40	38		
	7	65	52	43	37	63	51	43	37	49	42	36	48	41	36	47	40	36	34		
	8	61	47	39	33	59	47	38	33	45	38	33	44	37	32	43	37	32	30		
	9	57	43	35	30	55	43	35	30	42	34	29	41	34	29	39	33	29	27		
	10	53	40	32	27	52	39	32	27	38	31	27	38	31	27	37	31	26	25		

**Candela**

Angle	0-Deg	23-Deg	45-Deg	68-Deg	90-Deg
0	488	488	488	488	488
5	487	486	486	485	485
10	479	479	478	478	478
15	467	467	468	469	470
20	448	449	452	454	455
25	424	426	430	434	436
30	396	398	405	410	412
35	365	369	377	383	384
40	332	337	346	353	356
45	297	302	313	322	325
50	259	265	277	289	293
55	220	226	241	253	255
60	180	187	204	214	219
65	139	148	164	180	185
70	100	111	126	136	141
75	63	74	85	94	95
80	32	40	49	54	55
85	11	14	19	21	22
90	0	0	0	0	0

**Zonal Lumen Summary**

Zone	Lumens	% Lamp	% Fixture
0-30	376	N.A.	28.1
0-40	611	N.A.	45.7
0-60	1066	N.A.	79.7
0-90	1338	N.A.	100
40-90	726	N.A.	54.3
60-90	272	N.A.	20.3
90-180	0	N.A.	0
0-180	1338	N.A.	100

**Luminance Data**

Angle in Deg	0-Deg cd/sm	45-Deg cd/sm	90-Deg cd/sm
45	4918	5183	5382
55	4491	4920	5206
65	3851	4544	5126
75	2850	3846	4298
85	1478	2553	2956

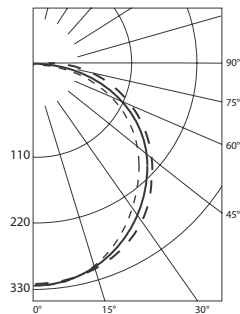

RM-WD-1L35-1x1  
877 Lumens  
12.2 Watts  
71.9 LPW  
LED ALM 2.0

Test Report: #P22411

**Coefficients of Utilization**

rc	Effective floor cavity reflectance 20%																				
	80%				70%				50%				30%				10%				0%
	rw	70	50	30	10	70	50	30	10	50	30	10	50	30	10	50	30	10	0		
RCR	0	119	119	119	119	116	116	116	116	111	111	111	106	106	106	102	102	102	100		
	1	109	104	100	96	106	102	98	95	98	94	92	94	91	89	90	88	86	84		
	2	99	91	84	78	96	89	83	77	85	80	76	82	78	74	79	76	72	70		
	3	90	80	72	65	88	78	71	65	75	69	64	73	67	62	70	65	61	59		
	4	83	71	62	55	80	69	61	55	67	60	54	65	58	53	62	57	53	51		
	5	76	63	54	48	74	62	54	47	60	53	47	58	52	46	56	50	46	44		
	6	70	57	48	42	68	56	48	41	54	47	41	53	46	41	51	45	40	38		
	7	65	52	43	37	63	51	43	37	49	42	36	48	41	36	47	40	36	34		
	8	61	47	39	33	59	47	38	33	45	38	33	44	37	32	43	37	32	30		
	9	57	43	35	30	55	43	35	30	42	34	29	41	34	29	39	33	29	27		
	10	53	40	32	27	52	39	32	27	38	31	27	38	31	27	37	31	26	25		

**Candela**

Angle	0-Deg	23-Deg	45-Deg	68-Deg	90-Deg
0	320	320	320	320	320
5	319	319	318	318	318
10	314	314	314	313	313
15	307	307	307	308	308
20	294	295	296	298	298
25	278	279	282	285	286
30	260	262	266	269	270
35	239	242	247	251	252
40	218	221	226	231	233
45	194	198	205	211	213
50	169	173	182	189	192
55	144	148	158	166	167
60	117	123	134	140	144
65	91	98	108	118	121
70	65	72	83	89	93
75	42	49	56	61	62
80	22	26	32	35	36
85	7	9	12	14	14
90	0	0	0	0	0

**Zonal Lumen Summary**

Zone	Lumens	% Lamp	% Fixture
0-30	247	N.A.	28.1
0-40	401	N.A.	45.7
0-60	699	N.A.	79.7
0-90	877	N.A.	100
40-90	476	N.A.	54.3
60-90	178	N.A.	20.3
90-180	0	N.A.	0
0-180	877	N.A.	100

**Luminance Data**

Angle in Deg	0-Deg cd/sm	45-Deg cd/sm	90-Deg cd/sm
45	3213	3395	3527
55	2940	3225	3409
65	2521	2992	3352
75	1900	2534	2805
85	940	1612	1881