

Project Name: _____ Type: _____ Quantity: _____

INTENDED USE

The **Spruce LED Architectural Landscape Path Light** is a unique lighting fixture offering quality and durability with a naturally etched finish designed to last. The Spruce LED Architectural Landscape Path Light is used to accent and create dramatic effect while providing a great source of lighting.

FEATURES

- W** 4.875" x **H** 21"
- Finish:** PVD Satin
- Construction:** Solid Brass
- Type:** Path Light
- Voltage:** 9-15V
- Wattage:** 2W or 3W
- Beam Spread:** 120°
- Lumens:** 150 lm or 350 lm
- Dimmable**
- Mounting:** 1/2" NPT Dual Fin Spike
- Included **Warranty:** LED Component: 5 Years. Housing: Lifetime (Labor not included)
- Listings:** ETL/cETL wet-location rated, Made in America

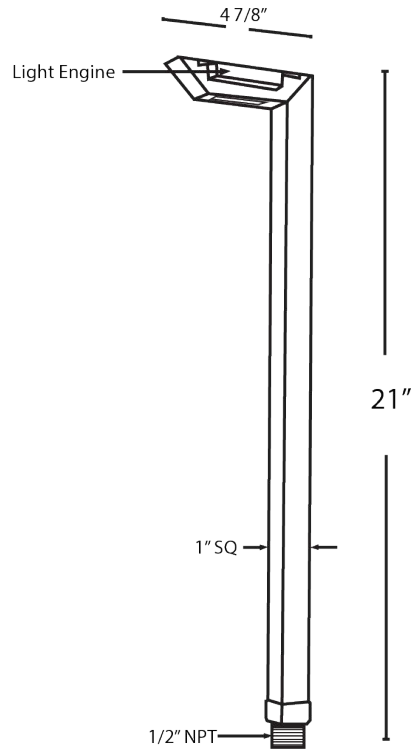

Alcon Lighting 9066 Spruce LED Architectural Landscape Contemporary Path Light



ORDERING INFORMATION Example: [9066-2-40K-MBR](#)

Model	Wattage Lumens	Color Temp	Finish			
9066 Spruce	2 2W 150 lm	27K 2700K	MBR	Matte Bronze	VE	Verde
	3 3W 350 lm	40K 4000K	PVDS	PVD Satin	RC	Raw Copper
		65K 6500K	BK	Black	RU	Rusty
		TF Turtle Friendly	MO	Moss	PVDP	PVD Polished
		(4 wk lead time)	AB	Aged Brass		