

FIXTURE SPECIFICATIONS

Project Name:

Type:

Quantity:

INTENDED USE

Use our architectural-grade, magnetic low-voltage LED landscape path light to illuminate residential and commercial exterior landscaping, such as gardens and pathways. The 4" width light, diecast in antique-styled brass, is also available in stainless steel.

FEATURES

Model Number: 9083

W 4" x H 22" D 4"

Lamp: LED Bi-Pin

Finish: Antique Bronze

Construction: Solid Die Cast Brass

Weight: 3 lbs

Voltage: 12V

Lumens: 110lms

Dimming: Magnetic Low Voltage (MLV)

Color Temp: 2700K

Mounting: 1/2" PVC Spike Included

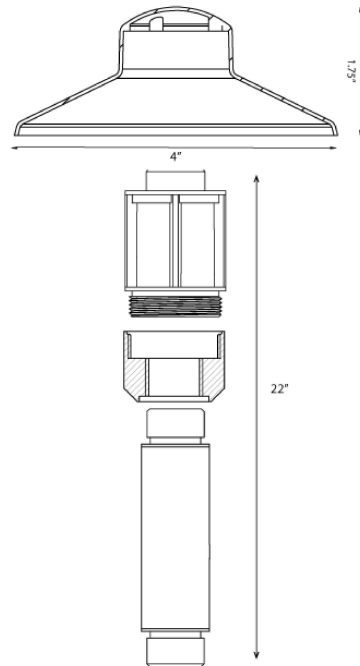

ORDERING INFORMATION Example: (9083-20)

Model	Wattage	Optional
9083	Signal	
	20	1.5W
	35	3W
		LV62
		Tree Mount