

FEATURES & SPECIFICATIONS

INTENDED USE

The **Shrine Low Voltage LED Architectural Landscape Path Light Fixture** is the ideal outdoor lighting solution for illuminating pathways and gardens in residential and commercial settings. The Shrine Low Voltage LED Architectural Landscape Path Light Fixture features high quality durability and energy efficiency.

DETAILS

- Model Number:** 9076
- W 6" x H 19" D 6"**
- Lamp:** LED Bi-Pin
- Finish:** Antique Bronze
- Construction:** Solid Die Cast Brass
- Weight:** 4 lbs

ADDITIONAL FEATURES

- Voltage:** 12V
- Lumens:** 110lms
- Dimming:** Magnetic Low Voltage (MLV)
- Color Temp:** 2700K
- Mounting:** 1/2" PVC Spike Included

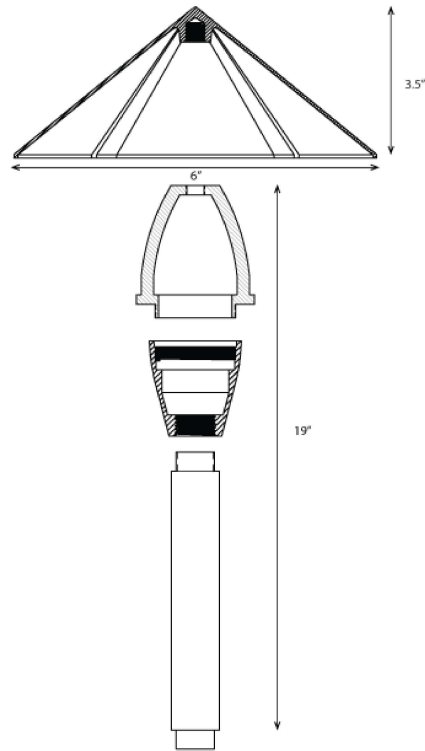

Ordering Information:

Example: (9076)

Model	Wattage	Optional
9076 Shrine	20 1.5W 35 3W	LV62 Tree Mount