

FEATURES & SPECIFICATIONS

INTENDED USE

The **Bucket Low Voltage LED Architectural Landscape Path Light Fixture** is the ideal outdoor lighting solution for illuminating pathways and gardens in residential and commercial settings. The Bucket Low Voltage LED Architectural Landscape Path Light Fixture features high quality durability and energy efficiency.

DETAILS

- Model Number:** 9070
- W** 3.5" **x H** 15" **D** 3.5"
- Lamp:** LED Bi-Pin
- Finish:** Antique Bronze
- Construction:** Solid Die Cast Brass
- Weight:** 2.5 lbs

ADDITIONAL FEATURES

- Voltage:** 12V
- Lumens:** 110lms
- Dimming:** Magnetic Low Voltage (MLV)
- Color Temp:** 2700K
- Mounting:** 1/2" PVC Spike Included

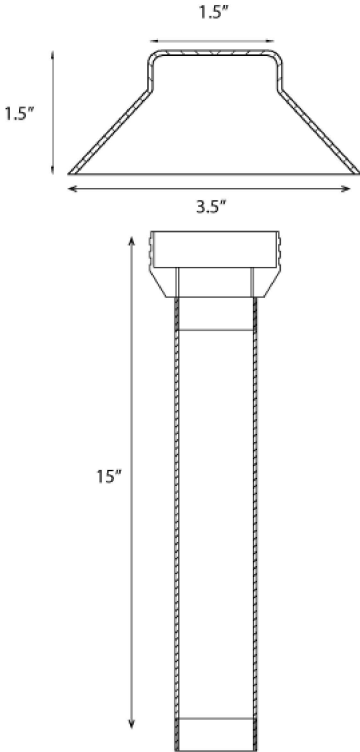

Ordering Information:

Example: (9070-AB-20)

Model	Finish	Wattage	Optional
9070	AB	20	LV62
Bucket	Antique Bronze	1.5W	Tree Mount
	SS	3W	
	Stainless Steel		