

FEATURES & SPECIFICATIONS

INTENDED USE

The **Mabel Landscape Architectural LED Path Light** is designed with durable, heat resistant lens and a silicone sealed gasket to protect from water, moisture, and insects. The Mabel is an ideal solution for landscape applications looking for quality and energy efficient lighting.



DETAILS

- Shroud:** W 1.75" x L 4.75"
- Stem:** Solid Brass 24" Pipe with 1/2" NPT on Bottom
- Construction:** Corrosion Resistant Cast Brass
- Lens:** Clear and Heat Resistant Flat Glass
- Socket:** Top Grade Ceramic Bi-Pin Socket with Retention Clip
- Silicone Gasket:** Weather Tight Protection
- Mounting:** Standard Injection Molded Spike with 1/2" NPT Threaded Female Hub
- Knuckle:** Adjustable Cast Brass with Thumb Screw
- Wiring:** 3 FT 18-2 Direct Burial Cord
- Electrical:** Remote 12V Transformer Required
- Lamp Equivalent:** 12V MR16 Halogen 50W Max

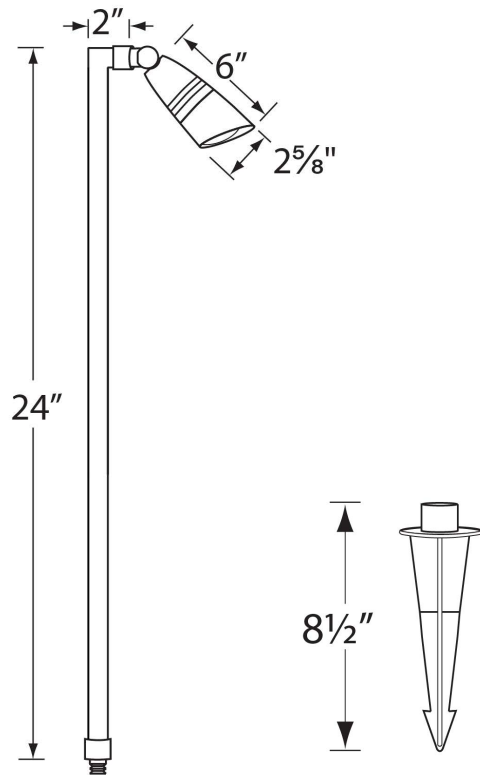

ADDITIONAL FEATURES

- Voltage:** 9-17V
- Life:** 50,000 Hours
- Listings:** Limited Lifetime Warranty on Housing and Stem  
5 Years Warranty on LED Component

Ordering Information:

Example: (9107-3W15)

Model	Wattage   Lumens   Color Temp   Beam
9107	<b>3W15</b> 3.5 watts / 270 lms / 2700K / 15° Spot
	<b>3W45</b> 3.5 watts / 270 lms / 2700K / 45° Flood
	<b>3W60</b> 3.5 watts / 270 lms / 2700K / 60° Wide Flood
	<b>5W15</b> 5 watts / 470 lms / 3000K / 15° Spot
	<b>5W38</b> 5 watts / 470 lms / 3000K / 38° Flood
	<b>5W60</b> 5 watts / 470 lms / 3000K / 60° Wide Flood

Options	
<b>SNP<sup>1</sup></b>	MR16 Snap On Holder
<b>CL<sup>2</sup></b>	Color Lens
<b>LS</b>	Linear Spread Lens
<b>FR</b>	Frosted Lens
<b>PR</b>	Prismatic Lens
<b>HC</b>	Honeycomb Louver

<sup>1</sup>Snap On Holder required to hold lenses and louver  
<sup>2</sup>Please Specify Color:  
 AM - Amber  
 BL - Blue  
 GR - Green  
 RD - Red  
 YL - Yellow