

FEATURES & SPECIFICATIONS

INTENDED USE

The **Easton Landscape Architectural LED Drive-Over Rated Well Light** is designed with durable, tempered lens and a silicone sealed gasket to protect from water, moisture, and insects. The Easton is an ideal solution for landscape applications looking for quality and energy efficient lighting.



DETAILS

W 3.875" x **L** 14.5" x **Dia** 3.875"

Construction: Fixture Mounted with Stainless Steel Retention Clips Inside PVC Sleeve

Lens: Clear, Tempered, and Heat Resistant Convex Glass
Extra Flat Lens Included

Socket: Top Grade Ceramic Bi-Pin Socket with Retention Clip

Gasket: Weather Tight Protection

Mounting: In-Ground Direct Burial or Concrete Encasement

Lamp: 12V MR16 Halogen 50W Max

Wiring: 3 FT 18-2 SJT-W Direct Burial Cord

Electrical: Remote 12V Transformer Required

Finish: Cast Brass

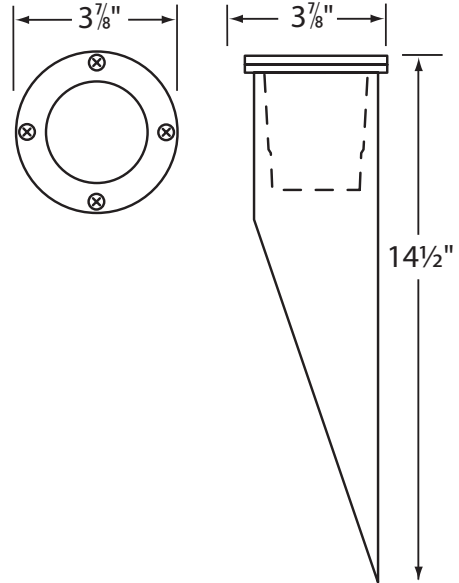

ADDITIONAL FEATURES

Voltage: 9-17V

Life: 50,000 Hours

Listings: Limited Lifetime Warranty on Fixture

Ordering Information:

Example: (9020-CB-3W15-SNP-CL-RD)

| Model | Wattage Lumens Color Temp Beam | Options |
|---------|--|--|
| 9020-CB | 3W15 3.5 watts / 270 lms / 2700K / 15° Spot 3W45 3.5 watts / 270 lms / 2700K / 45° Flood 3W60 3.5 watts / 270 lms / 2700K / 60° Wide Flood 5W15 5 watts / 470 lms / 3000K / 15° Spot 5W38 5 watts / 470 lms / 3000K / 38° Flood 5W60 5 watts / 470 lms / 3000K / 60° Wide Flood | SNP¹ MR16 Snap On Holder CL² Color Lens LS Linear Spread Lens FR Frosted Lens PR Prismatic Lens HC Honeycomb Louver |

¹Snap On Holder required to hold lenses and louver

²Please Specify Color:

- AM - Amber
- BL - Blue
- GR - Green
- RD - Red
- YL - Yellow