

SHOP NOW >

FEATURES & SPECIFICATIONS

INTENDED USE

The **Alcon Lighting Optic LED Wallpack Round Outdoor Vandal Proof Luminaire** features high durability and performance designed to withstand tough environments. The Optic LED Wallpack is ideal for schools, parking garages, office complexes, and other outdoor applications.

DETAILS

Diameter: 14"

Construction: Die-cast aluminum front frame and housing, nickel-plated stainless steel hardware

Finish: Textured powdercoat paint over chromate conversion coating

ADDITIONAL FEATURES

Voltage: 120-277

Wattage: 20W

Lumens: 1674 lms

CRI: 80+

Dimming: 0-10V to 10%

Drive Current: 525 mA

Lens: Polycarbonate Opal

Light Distribution: Type IV

Operating Temperature: -40° to 50°C Max Ambient

Life: L70 Rating - 100,000 Hrs, L80 Rating - 88,000 Hrs

Warranty: 5 Years Carefree for Parts & Components (Labor Not Included)

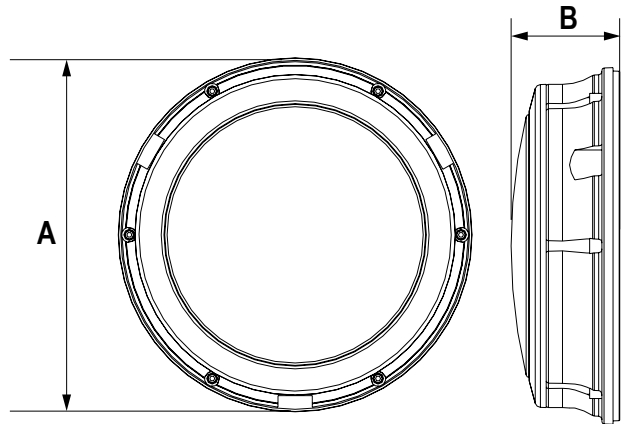

	Open	Cross	Eyelid
A	12.5"	12.5"	12.5"
B	3.94"	4.38"	4.38"

Ordering Information:

Example: (11231-50K-O-FP-SP)

Model



11231
Optic

Color Temp



50K 5000K

Guard



O Open
C Cross
E Eyelid

Finish



(Blank) Bronze (Standard)
WH White
CU Custom

Options

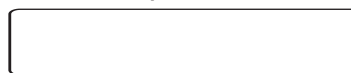

SP Surge Protection
EM Emergency Battery
PC1 Photocell (120V)
PC2 Photocell (277V)
MS2 Microwave Sensor w/ Dimming (Internally Mounted, 120-277V)