

HSLED13A

Bullet shape die cast aluminum flood with spotlighting for over 40 feet away. 13 watt LED High Performance Light Engine.

Color: Bronze

Weight: 3.5 lbs

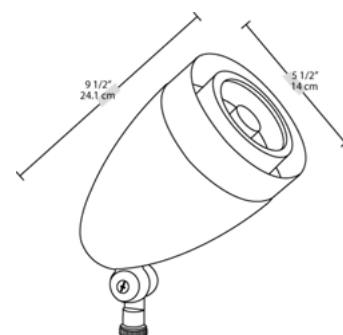

LED Info

Watts: 13
 Color Temp: 5000K (Cool)
 Color Accuracy: 67
 L70 Lifespan: 0
 LM79 Lumens: 787
 Efficacy: 52 LPW

Driver Info

Type: Constant Current
 120V: 0.13 A
 208V: 0.08 A
 240V: 0.07 A
 277V: 0.06 A
 Input Watts: 15W
 Efficiency: 87%

Technical Specifications

UL Listing:

Suitable for wet locations. Suitable for mounting within 4' of the ground.

Spotlight Distribution:

Beam Angle of 11 degrees and Field Angle of 24 degrees enables the HSLED to produce a very narrow spot distribution.

Country of Origin :

Designed by RAB in New Jersey and assembled in the USA by IBEW Local 3

Buy American Act Compliant :

This product is a COTS item manufactured in the United States, and is compliant with the Buy American Act.

Recovery Act (ARRA) Compliant :

This product complies with the 52.225-21 "Required Use of American Iron, Steel, and Manufactured Goods-- Buy American Act-- Construction Materials (October 2010)

Trade Agreements Act Compliant :

This product is a COTS item manufactured in the United States, and is compliant with the Trade Agreements Act.

GSA Schedule :

This product is suitable for listing on the GSA Schedule of the US General Services in accordance with FAR Subpart 25.4

LEDs:

13 Watt high output, long-life LED.

Driver:

Constant Current, Class 2, 100-277V, 50-60Hz, 100-240VAC 0.3-0.15A, 277VAC 0.15A

Lumen Maintenance:

50,000-Hour Life Based on LM-80 Tests.

Fixture Efficacy:

52 Lumens per Watt

Surge Protection:

4 KV

NEMA Type:

2H x 2v Beam Spread

Ambient Temperature:

Suitable for use in 40C ambient temperatures

Cold Weather Starting:

The minimum starting temperature is -40F/-40C

Color Stability:

RAB LED products exceed industry standards for chromatic stability.

Color Accuracy:

67 CRI

Color Temperature (Nominal CCT):

5000K

Color Uniformity:

RAB's range of CCT (Correlated Color Temperature) follows the guidelines of the American National Standard for (SSL) Products, ANSI C78.377-2008.

Heatsink:

Cast aluminum patent pending thermal management system for optimal heat sinking. The HSLED is designed for cool operation, most efficient output and maximum LED life by minimizing LED junction temperature.

HSLED13A - continued

Housing:

Precision die-cast aluminum housing, hood and mounting arm.

Gaskets:

High Temperature Silicone

Finish:

Chip and fade resistant polyester powder coat finish.

Warranty:

RAB LED fixtures give you peace of mind because both the fixture and light engine components are backed by RAB's 5 Year Warranty. For more information, .

Green Technology:

Mercury and UV free, and RoHS compliant.

California Title 24:

HSLED complies with California Title 24 building and electrical codes.

IESNA LM-79 & IESNA LM-80 Testing:

RAB LED luminaires have been tested by an independent laboratory in accordance with IESNA LM-79 and 80, and have received the Department of Energy "Lighting Facts" label.

Patents:

The design of the HSLED is protected by patents pending in US, Canada, China, Taiwan and Mexico.