

## Maestro Wireless Local Controls

Maestro Wireless controls function much like standard dimmers and switches, but can be controlled from Pico™ wireless controls and Lutron® ceiling mount occupancy/vacancy sensors. Local lighting controls are useful in locations where single circuits of lighting need to be dimmed or switched.

Maestro Wireless dimmers incorporate advanced features such as fade on/fade off, long fade off, and rapid full on.

Maestro Wireless local controls include a Front Accessible Service Switch (FASS™) for safe lamp replacement. Maestro Wireless controls install in single-pole or multi-location applications.

### Model Numbers

#### Dimmers

Halogen/Incandescent/Magnetic Low-voltage	
MRF2-600M-XX	600 W Incandescent Dimmer 120 V~
MRF2-6MLV-XX	600 W/600 VA Incandescent/MLV Dimmer 120 V~
MRF2-6ND-120-XX*	600 W/600 VA Spec Grade Neutral wire Dimmer 120 V~
MRF2-10D-120-XX	1000 W/1000 VA Spec Grade Dimmer 120 V~

#### 3-wire Fluorescent—Available April 2010

MRF2-F6AN-DV-XX*	6 A 3-wire Fluorescent Spec Grade Neutral wire Dimmer 120–277 V~
------------------	--

#### Switches

##### Lighting and motor loads

MRF2-6ANS-XX*	6 A Lighting/3 A Fan (1/10 HP motor), Electronic Switch 120 V~
MRF2-8ANS-120-XX*	8 A Lighting, 5.8 A Fan (1/4 HP motor), Spec Grade Electronic Switch 120 V~
MRF2-6ANS-277-XX*	6 A Lighting, Spec Grade Electronic Switch 277 V~
MRF2-8S-DV-XX	8 A Lighting, 3 A Fan (1/10 HP motor, 120 V~ only), Spec Grade Electronic Switch 120–277 V~, NO NEUTRAL WIRE REQUIRED

\* NEUTRAL WIRE REQUIRED.

Dimmer



Companion Dimmer



Switch



Companion Switch



#### Companion Controls

##### Claro® Gloss Finishes

MA-R-XX	Companion Dimmer 120 V~
MA-AS-XX	Companion Switch 120 V~
MA-R-277-XX	Companion Dimmer 277 V~
MA-AS-277-XX	Companion Switch 277 V~

##### Satin Colors® Satin Finishes

MSC-AD-XX	Companion Dimmer 120 V~
MSC-AS-XX	Companion Switch 120 V~
MSC-AD-277-XX	Companion Dimmer 277 V~
MSC-AS-277-XX	Companion Switch 277 V~

“XX” in the model number represents color/finish code.

Job Name:	Model Numbers:
Job Number:	

### Colors and Finishes

#### Gloss Finishes



White  
WH



Ivory  
IV



Hot  
HT



Merlot  
MR



Plum  
PL



Turquoise  
TQ



Almond  
AL

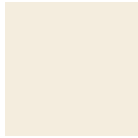

Light  
Almond  
LA



Taupe  
TP

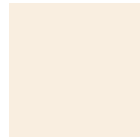

Eggshell  
ES

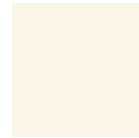

Biscuit  
BI



Snow  
SW



Gray  
GR



Brown  
BR



Palladium  
PD



Midnight  
MN



Sienna  
SI

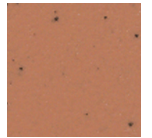

Terracotta  
TC



Black  
BL



Greenbriar  
GB

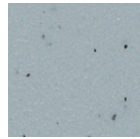

Bluestone  
BG

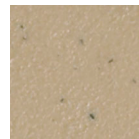

Mocha  
Stone  
MS



Goldstone  
GS

Due to printing limitations, colors and finishes shown cannot be guaranteed to perfectly match actual product colors.

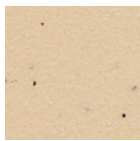

Desert Stone  
DS

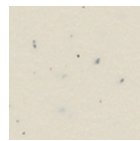

Stone  
ST

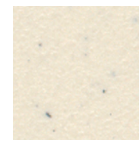

Limestone  
LS

#### Metal Finish (wallplate only)



Stainless  
Steel SS

When using Stainless Steel wallplates, it is recommended to order the controls in Black (BL) or Midnight (MN).

Job Name:	Model Numbers:
Job Number:	

### Load Type and Capacity

Control	Voltage	Load Type	Minimum Load	Maximum Load			Neutral Connection
				Not Ganged	End of Gang	Middle of Gang	
MRF2-6ND-120 <sup>1,2,7</sup>	120 V~	Incand.	25 W	600 W	500 W	400 W	YES
		MLV <sup>2</sup>	25 W/VA	450 W/ 600 VA	400 W/ 500 VA	300 W/ 400 VA	
MRF2-600M <sup>1,7</sup>	120 V~	Incand.	50 W	600 W	500 W	400 W	NO
MRF2-6MLV <sup>1,2,7</sup>	120 V~	MLV <sup>2</sup>	50 VA	450 W/ 600 VA	400 W/ 500 VA	300 W/ 400 VA	NO
MRF2-10D-120 <sup>1,2,7</sup>	120 V~	Incand.	50 W	1000 W	800 W	650 W	NO
		MLV <sup>2</sup>	50 W/VA	800 W/ 1000 VA	600 W/ 800 VA	500 W/ 650 VA	
MRF2-F6AN-DV <sup>6,9</sup>	120-277 V~	Lighting	1 ballast 0.05 A	6 A	5 A	3 A	YES
MRF2-8ANS-120 <sup>3,5</sup>	120 V~	Lighting	25 W	8 A	6.5 A	5 A	YES
		Fan Motor	0.2 A	1/4 HP 5.8 A	1/4 HP 5.8 A	1/6 HP 4.4 A	
MRF2-6ANS <sup>3</sup>	120 V~	Lighting	25 W	6 A	5 A	3.5 A	YES
		Fan Motor	0.2 A	1/10 HP 3 A	1/10 HP 3 A	1/10 HP 3 A	
MRF2-6ANS-277 <sup>4</sup>	277 V~	Lighting	25 W	6 A	5 A	3.5 A	YES
MRF2-8S-DV <sup>4</sup>	120-277 V~	Lighting	40 W	8 A	8 A/7 A <sup>8</sup>	7 A	NO
	120 V~	Fan Motor	0.4 A	1/10 HP 3 A	1/10 HP 3 A	1/10 HP 3 A	

- <sup>1</sup> Dimmer Load Type: -6ND, -6MLV and -10D are designed for use with permanently installed incandescent, magnetic low-voltage, or tungsten halogen only. -600M is designed for use with permanently installed incandescent or tungsten halogen only. Do not install dimmers to control receptacles or motor-operated appliances.
- <sup>2</sup> Low-Voltage Applications: Use -6ND, -6MLV and -10D with magnetic (core and coil) low-voltage transformers only. Not for use with electronic (solid-state) low-voltage transformers. Operation of a low-voltage circuit with lamps inoperative or removed may result in transformer overheating and premature failure. Lutron strongly recommends the following:
  - Do not operate low-voltage circuits without operative lamps in place.
  - Replace burned-out lamps as quickly as possible.
  - Use transformers that incorporate thermal protection or fused transformer primary windings to prevent transformer failure due to overcurrent.
- <sup>3</sup> Switch Load Type: -8ANS-120 is designed for use with permanently installed lighting loads and with fan motor loads up to 1/4 HP (5.8 A).  
 -6ANS is designed for use with permanently installed lighting loads and with fan motor loads up to 1/10 HP (3 A).  
 -8S-DV is designed for use with permanently installed lighting loads and with fan motor loads up to 1/10 HP (3 A, 120 V~ only).
- <sup>4</sup> Switch Load Type: -6ANS-277 is designed for use with permanently installed lighting loads.
- <sup>5</sup> For loads larger than 8 A @ 120 V~, the -8ANS-120 switch can be used with the PHPM-SW-DV-WH power booster. For loads larger than the MRF2-6ANS-277 capacity of 6 A @ 277 V~, the -8ANS-120 can also be used with the PHPM-SW-DV-WH power booster to switch 277 V~ loads. Please note that in this application, the -8ANS-120 switch is providing an input at 120 V~ and the power booster is switching 277 V~.
- <sup>6</sup> Can control the following power boosters/load interfaces: Phase-adaptive Power Modules (PHPM-WBX-DV-WH), 3-wire Fluorescent Power Modules (PHPM-3F-DV-WH), Tu-Wire® Fluorescent Power Modules (PHPM-PA-DV-WH), and 0-10 V (GRX-TVI).
- <sup>7</sup> Can control the following power booster/load interface: Hi-Power 2•4•6™ Boosters (HP-2, HP-4, HP-6) for control of most popular lighting sources including Lutron® 3-wire line voltage control fluorescent dimming ballasts (Hi-lume®, Hi-lume Compact SE™, Eco-10®, and EcoSystem®).
- <sup>8</sup> Maximum load for double gang application is 8 A. Triple gang application derates maximum load to 7 A.
- <sup>9</sup> Dimmer Load Type: -F6AN is designed for use with permanently installed 3-wire line voltage control fluorescent ballasts or LED drivers only (Hi-lume, Hi-lume Compact SE, Eco-10, and EcoSystem).

Job Name:	Model Numbers:
Job Number:	

## Specifications

### Regulatory Approvals

- UL Listed.
- CSA Certified.
- FCC Approved. Complies with the limits for a Class B digital device, pursuant to Part 15 of the FCC Rules.
- Industry Canada Certified.

### Power

Operating voltage:

120 V~ 60 Hz

277 V~ 60 Hz (-6ANS-277, -8S-DV, -F6AN-DV)

### Key Design Features

#### Dimmers

- On a single-tap, lights fade UP or DOWN.
- On a double-tap, lights go to full ON.
- When ON, press and hold to engage 20-second fade to OFF.
- Light levels can be fine-tuned by pressing and holding the dimming rocker until the desired light level is reached.
- Two-wire dimmers available.

#### Switch

- On a single-tap, lights turn ON or OFF.
- Two-wire switches available.

#### All RF Local Controls

- Tested to withstand electrostatic discharge without damage or memory loss, in accordance with IEC 61000-4-2.
- Tested to withstand surge voltages without damage or loss of operation, in accordance with IEEE C62.41-1991 Recommended Practice on Surge Voltages in Low-Voltage AC Power Circuits.
- Controls always operate locally and do not require system control.

- Power failure memory: should power be interrupted, the control will return to its previously set level prior to the interruption when power is restored.
- Uses conventional 3-way and 4-way wiring.
- Multiple location control from Dimmer/Switch and up to 9 Companion Dimmer(s)/Switch(es).
- Use Lutron® Designer (Claro® and Satin Colors®) wallplates or designer-style wallplates from other manufacturers. Wallplates are sold separately.
- Lutron *Claro* and *Satin Colors* wallplates snap on with no visible means of attachment.
- Requires a 1-gang U.S. wallbox. 3½ in (89 mm) deep recommended, 2¼ in (57 mm) deep minimum.
- Green indicator lights.

### System Communications and Capacity

- *Maestro Wireless* controls communicate with the Pico™ wireless controls and ceiling mount occupancy sensors through radio frequency (RF).
- *Maestro Wireless* local controls must be located within 60 ft (18 m) line of sight or 30 ft (9 m) through walls, of a ceiling mount occupancy/vacancy sensor.
- *Maestro Wireless* local controls must be located within 100 ft (30 m) line of sight or 30 ft (9 m) through walls, of a Pico™ wireless control.
- Up to 10 *Maestro Wireless* controls can be configured to work together.

### Environment

- Ambient operating temperature: 32 °F to 104 °F (0 °C to 40 °C), 0%-90% humidity, non-condensing. Indoor use only.

### Warranty

- 1 Year Limited Warranty.

Job Name:	Model Numbers:
Job Number:	

### Operation

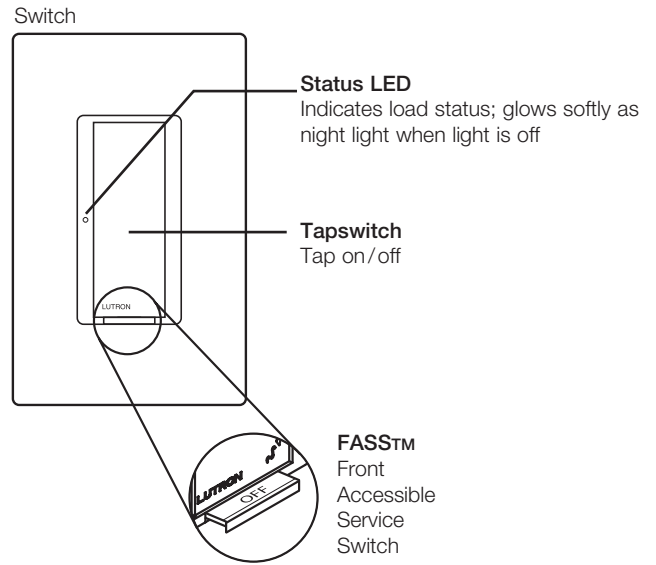
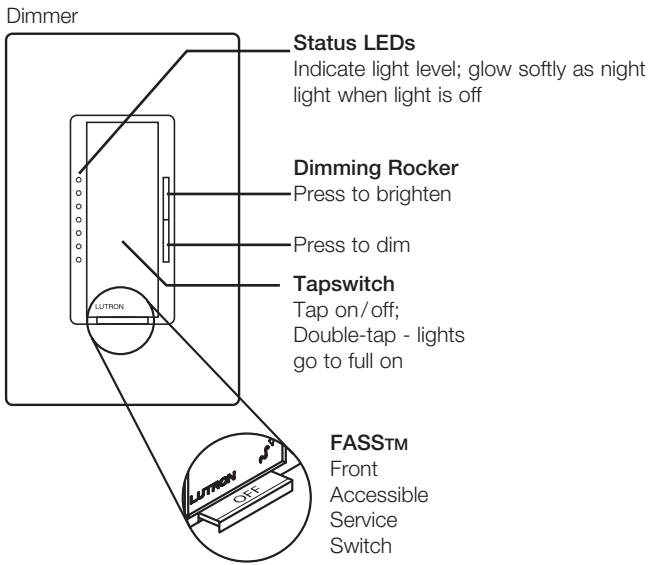

**IMPORTANT NOTICE:**  
**FASS** - Front Accessible Service Switch - to service load, remove power by pulling the *FASS* switch out completely on either the Dimmer/Switch or Companion Dimmer/Switch. After servicing load, push the *FASS* switch back in fully to restore power to the control.

### Mounting

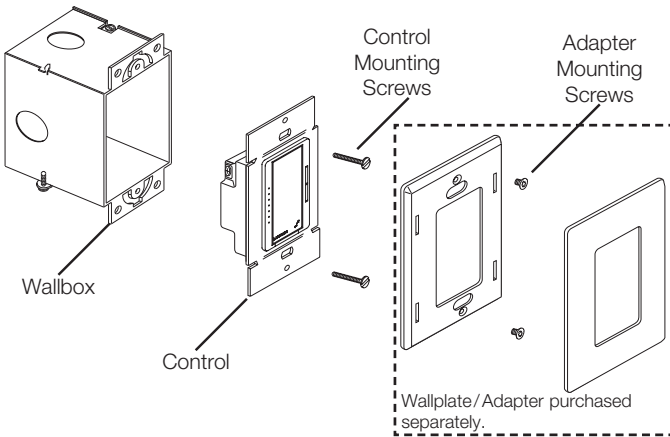

Job Name:	Model Numbers:
Job Number:	

### Dimensions

Front View

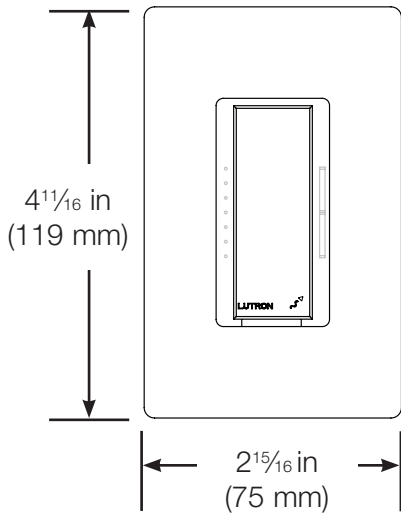

Side View

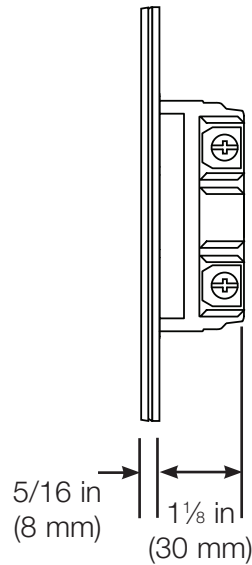

### Ganging and Derating

When ganging with other controls in the same wallbox, derating is required. See Load Type and Capacity chart. Only -8ANS controls have fins that need to be removed for multigang installations. No other controls have fins, but they must still be derated in multigang installations.

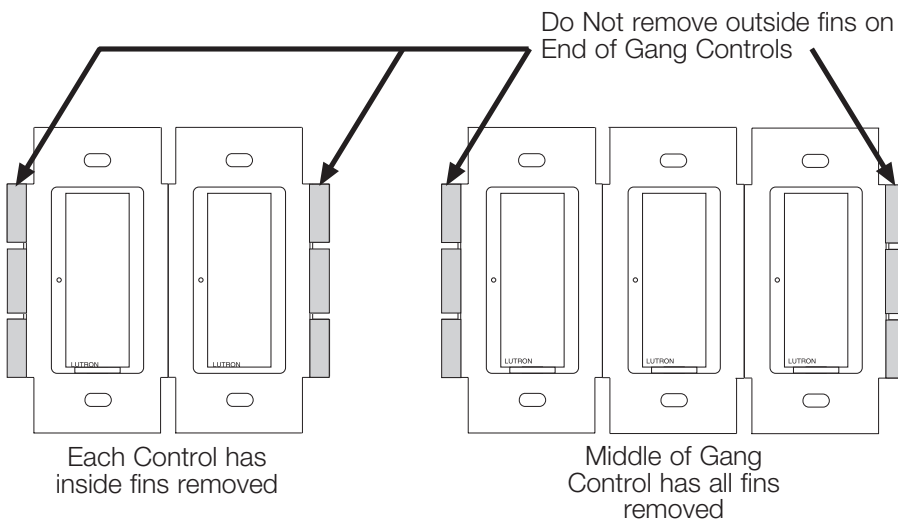

Job Name:	Model Numbers:
Job Number:	

## Wiring Diagrams

### Single Location Installation

-600M, -6MLV, -10D, -8S-DV

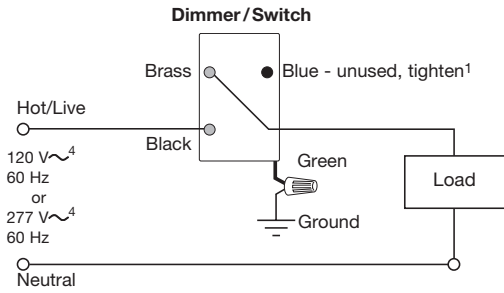

### Single Location Installation with Neutral

-6ND, -6ANS-120, -8ANS-120, -6ANS-277

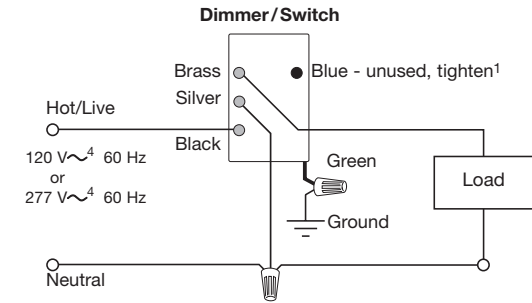

### Multi-Location Installation<sup>2</sup>

-600M, -6MLV, -10D with MA-R/MSC-AD; -8S-DV<sup>5</sup> with MA-AS/MA-AS-277 or MSC-AS/MSC-AS-277

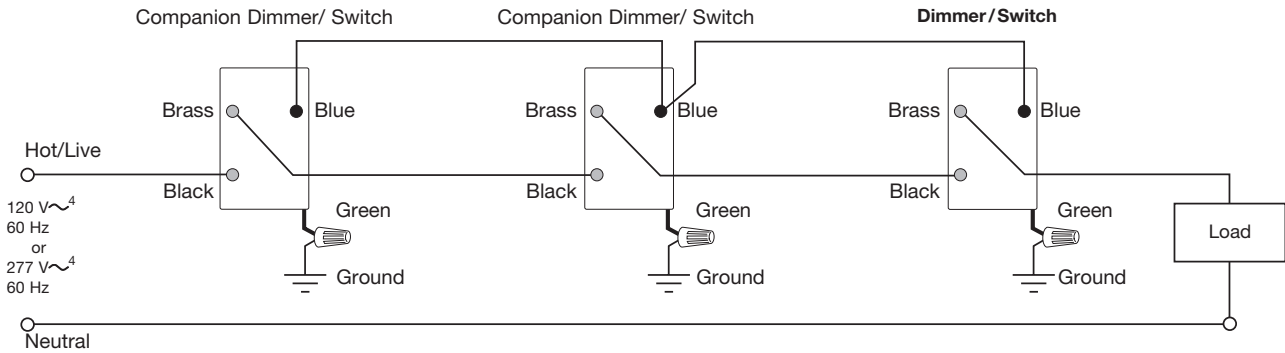

### Multi-Location Installation with Neutral<sup>2,3</sup>

-6ND with MA-R/MSC-AD; -6ANS-120, -8ANS-120 with MA-AS/MSC-AS; -6ANS-277 with MA-AS-277/MSC-AS-277

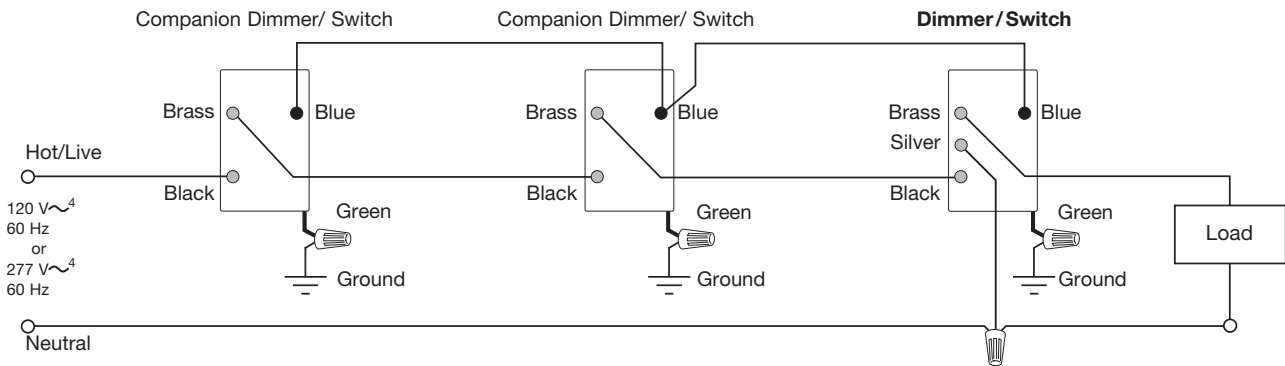

<sup>1</sup> When using controls in single location installations, tighten the blue terminal. **DO NOT** connect the blue terminal to any other wiring or to ground.

<sup>2</sup> Up to 9 *Maestro* Companion Dimmers/Switches may be connected to the *Maestro Wireless* Dimmer/Switch. Total blue terminal wire length may be up to 250 ft (76 m).

<sup>3</sup> Neutral wire Dimmers/Switches must be connected on the Load side of a multi-location installation.

<sup>4</sup> 120 V~ : -6ND, -6ANS-120, -8ANS-120  
277 V~ : -6ANS-277, 8S-DV

<sup>5</sup> Requires MA-AS/MSC-AS for 120 V~ applications, and MA-AS-277/MSC-AS-277 for 277 V~ applications.

Job Name:	Model Numbers:
Job Number:	

## Wiring Diagrams

### Single Location Installation with Neutral

-F6AN-DV

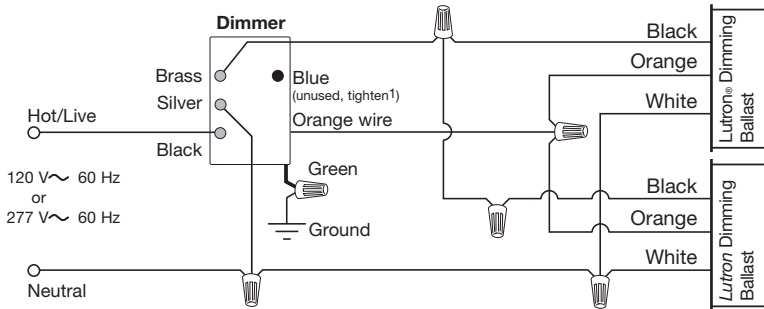

### Multi-Location Installation with Neutral<sup>2,3</sup>

-F6AN-DV with MA-R/MA-R-277 or MSC-AD/MS-C-AD-277<sup>4</sup>

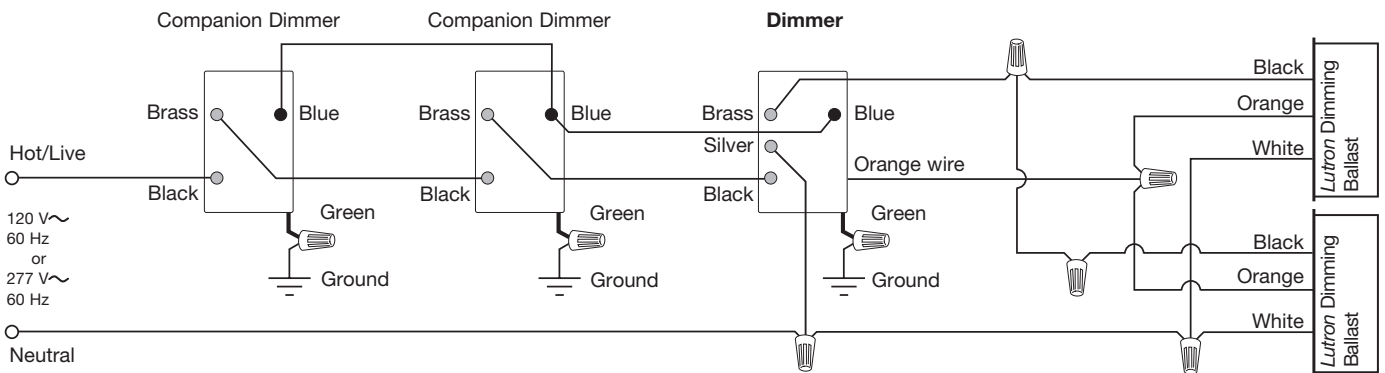

<sup>1</sup> When using controls in single location installations, tighten the blue terminal. **DO NOT** connect the blue terminal to any other wiring or to ground.

<sup>2</sup> Up to 9 *Maestro* Companion Dimmers may be connected to the *Maestro Wireless* Dimmer. Total blue terminal wire length may be up to 250 ft (76 m).

<sup>3</sup> Neutral wire Dimmers must be connected on the Load side of a multi-location installation.

<sup>4</sup> Requires MA-R/MS-C-AD for 120 V~ applications, and MA-R-277/MS-C-AD-277 for 277~ V applications.

Job Name:	Model Numbers:
Job Number:	



## Wiring Diagrams

### Single Location Installation with Power Booster Single Feed

-6ANS-120, -8ANS-120 with PHPM-SW-DV-WH

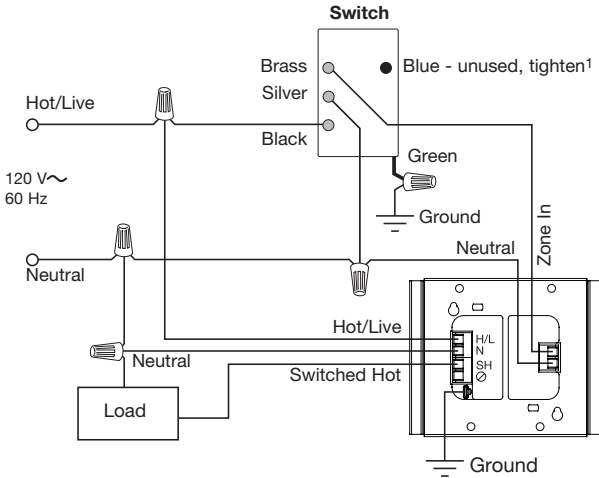

### Single Location Installation with Power Booster Dual Feed

-6ANS-120, -8ANS-120 with PHPM-SW-DV-WH

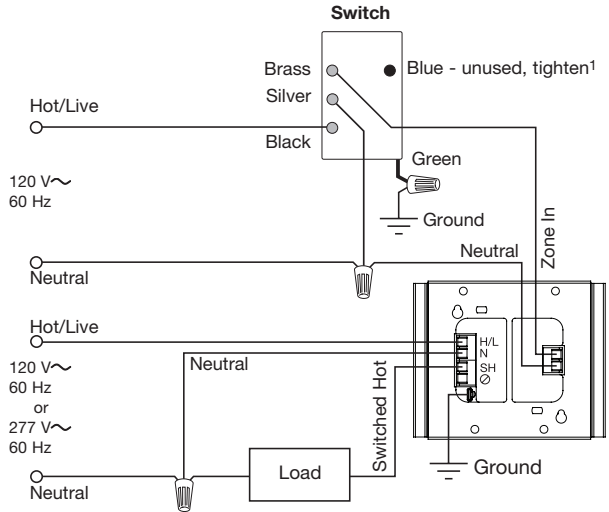

### Multi-Location Installation with Power Booster<sup>2,3</sup> Single Feed

-6ANS-120, -8ANS-120 with MA-AS/MSC-AS  
and PHPM-SW-DV-WH

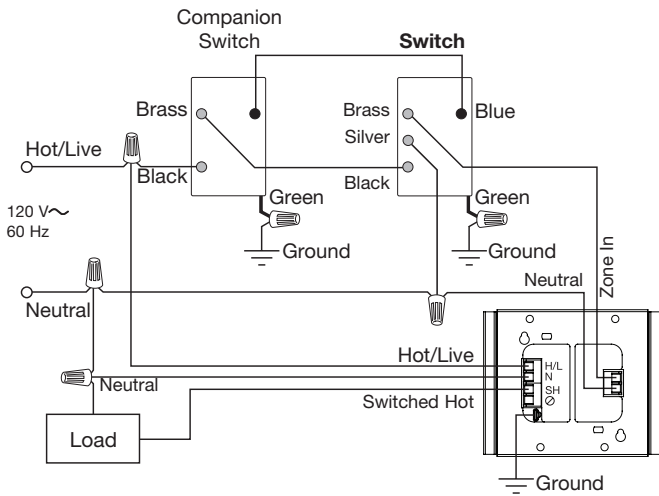

### Multi-Location Installation with Power Booster<sup>2,3</sup> Dual Feed

-6ANS-120, -8ANS-120 with MA-AS/MSC-AS  
and PHPM-SW-DV-WH

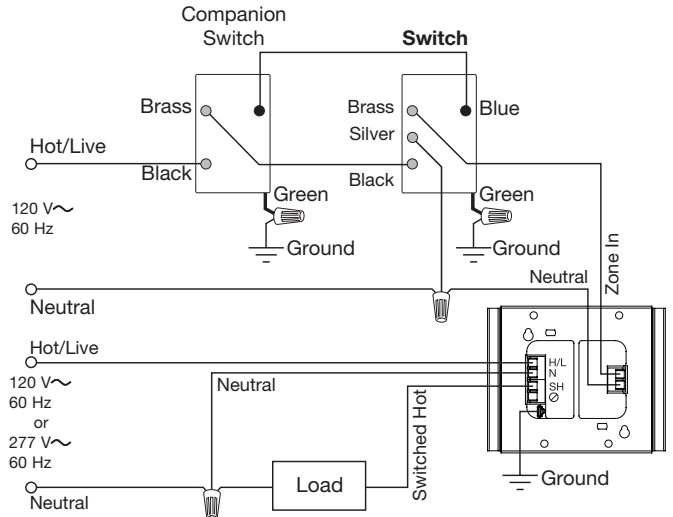

<sup>1</sup> When using controls in single location installations, tighten the blue terminal. **DO NOT** connect the blue terminal to any other wiring or to ground.

<sup>2</sup> Up to 9 *Maestro* Companion Switches may be connected to the *Maestro Wireless* Switch. Total blue terminal wire length may be up to 250 ft (76 m).

<sup>3</sup> Neutral wire Switches must be connected on the Load side of a multi-location installation.

Job Name:	Model Numbers:
Job Number:	

## Wiring Diagrams

### Single Location Installation with Power Booster Single Feed

-F6AN-DV with PHPM-3F-DV-WH, PHPM-PA-DV-WH, or PHPM-WBX-DV-WH

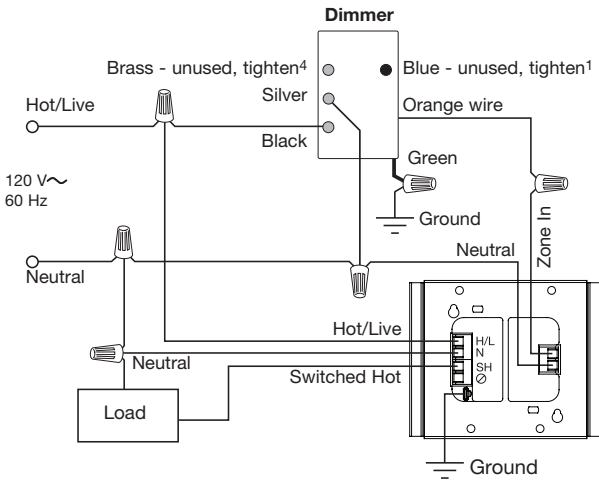

### Single Location Installation with Power Booster Dual Feed

-F6AN-DV with PHPM-3F-DV-WH, PHPM-PA-DV-WH, or PHPM-WBX-DV-WH

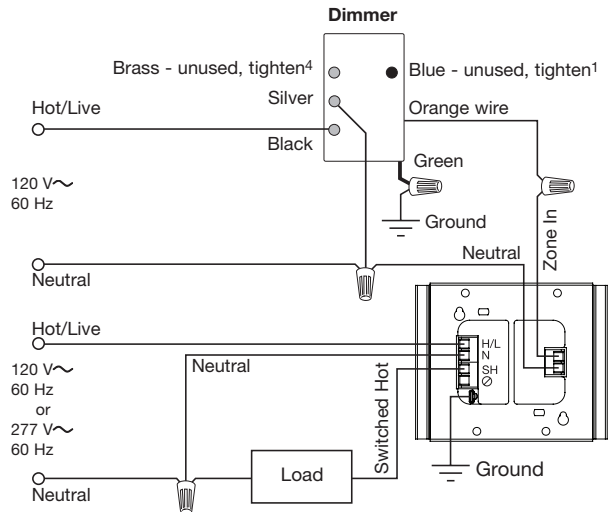

### Multi-Location Installation with Power Booster<sup>2,3</sup> Single Feed

-F6AN-DV with MA-R/MSC-AD and PHPM-3F-DV-WH, PHPM-PA-DV-WH, or PHPM-WBX-DV-WH

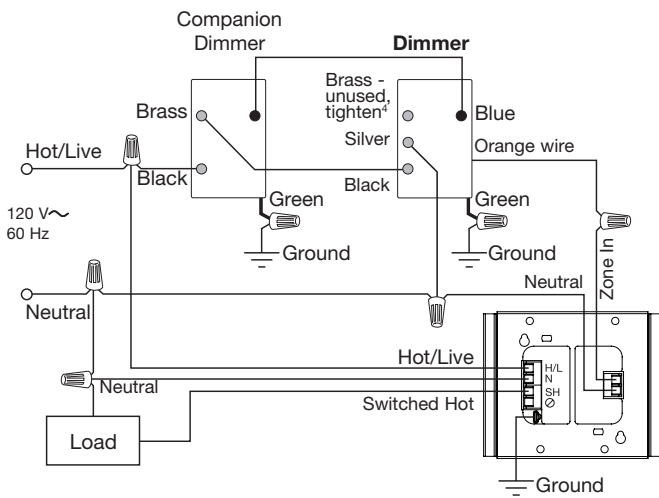

### Multi-Location Installation with Power Booster<sup>2,3</sup> Dual Feed

-F6AN-DV with MA-R/MSC-AD and PHPM-3F-DV-WH, PHPM-PA-DV-WH, or PHPM-WBX-DV-WH

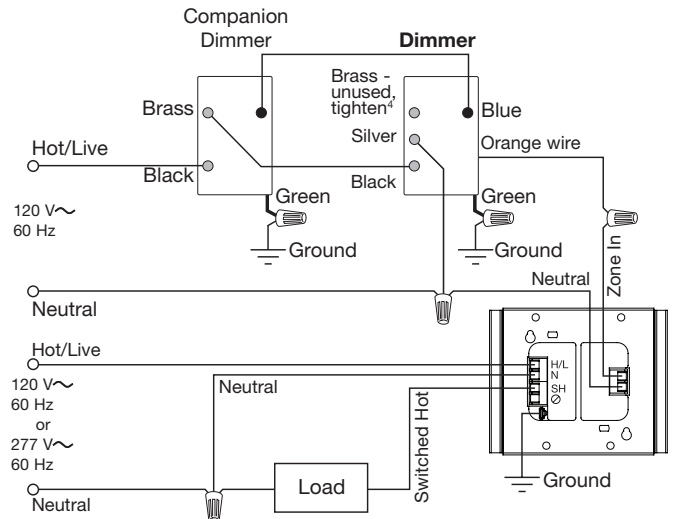

<sup>1</sup> When using controls in single location installations, tighten the blue terminal. **DO NOT** connect the blue terminal to any other wiring or to ground.

<sup>2</sup> Up to 9 *Maestro* Companion Dimmers may be connected to the *Maestro Wireless* Dimmer. Total blue terminal wire length may be up to 250 ft (76 m).

<sup>3</sup> Neutral wire Dimmers must be connected on the Load side of a multi-location installation.

<sup>4</sup> When using a PHPM, tighten the brass (Sw Hot) terminal. **DO NOT** connect the brass terminal to any other wiring or to ground.

Job Name:	Model Numbers:
Job Number:	