



ColorBlast Powercore

Vibrant, controllable color for interior and exterior architectural lighting

PHILIPS

ColorBlast Powercore

Vibrant, controllable color for interior and exterior architectural lighting

ColorBlast® Powercore high-performance LED fixtures combine rich, saturated, wall-washing color and color-changing effects with simplified installation. ColorBlast Powercore offers a single solution for both indoor and outdoor applications, while a range of beam angles make the fixture ideal for washing, grazing, floodlighting, and spot lighting. ColorBlast Powercore offers the efficiency and cost-effectiveness of Powercore® technology in a rugged die-cast aluminum housing. Low-profile mounting canopy, rotating mounting bracket, and locking fixture rotation offer exceptional versatility.

- Superior light output — ColorBlast Powercore fixtures produce saturated, full-color light output of up to 1418 lumens with light projection of up to 204 feet. A 23° beam for a soft-edge and a 10° beam for extended light projection support a wide range of lighting applications.
- Integrates patented Powercore technology — Powercore rapidly, efficiently, and accurately controls power output to fixtures directly from line voltage. The Philips Color Kinetics Data Enabler Pro merges line voltage with control data and delivers them to fixtures over a single standard cable, dramatically simplifying installation and lowering total system cost.
- Versatile light positioning — Locking canopy base offers friction-free rotation of up to 350°, and 110° fixture tilting lets you quickly aim the fixture without special tools.
- Easy installation — By providing line voltage directly to fixtures, Powercore eliminates the need for external power supplies and special wiring. Fixtures can be mounted to a junction box on a wall, ceiling, or floor. The canopy base allows for post-installation rotation without precise junction box positioning.
- Universal power input range — ColorBlast Powercore accepts power input of 100 – 240 VAC, allowing the installation of many units in a continuous run. A single Data Enabler Pro can run up to 30 ColorBlast Powercore fixtures at 100 VAC, 36 fixtures at 120 VAC, or 66 fixtures at 220 VAC, or 72 fixtures at 240 VAC, installed in series, depending on cable lengths and wire gauge.
- Industry-leading controls — ColorBlast Powercore works seamlessly with the complete Philips line of controllers, including ColorDial™ Pro, iPlayer® 3, and Light System Manager, as well as third-party controllers.
- Efficient and cost-effective — Replacing metal halide fixtures with ColorBlast Powercore fixtures can dramatically reduce electricity and maintenance costs while delivering superior consistency and uniformity of light and color.



Outdoor Rated

Fully sealed for maximum fixture life and IP66 rated for outdoor applications, ColorBlast Powercore fixtures meet or exceed specifications for use in wet locations. Rugged, die-cast aluminum housing is available in white or black powder-coated finish.

Versatile Installation Options

ColorBlast Powercore offers saturated, color-changing LED light, both indoors and outdoors. With its low-profile design, IP66-rated housing, multiple beam angles, and ease of installation and maintenance, ColorBlast Powercore is ideal for applications ranging from backlighting and display and signage lighting to floodlighting, facade- and wall-grazing, architectural detail highlighting, and artistic displays.

Philips offers a range of controllers to support installations from the simplest to the most complex. A simple application might use two ColorBlast Powercore fixtures with a ColorDial Pro controller to dramatically illuminate store window displays with pre-programmed color washes or fades. A larger installation might use Philips Color Kinetics iPlayer 3 controller and its ColorPlay® 3 light show authoring software to run transformative and imaginative custom light shows on dozens of ColorBlast Powercore fixtures installed in multiple interior or exterior locations.

Philips Color Kinetics Light System Manager, an Ethernet-based integrated controller and light show authoring system, cost-effectively enables large-scale, complex, and intricately designed installations. The LAX Gateway at Los Angeles International Airport (shown on the cover) uses Light System Manager and approximately 1,800 ColorBlast Powercore fixtures to generate color-changing light within 26 glass pylons ranging in height from 25 to 110 feet.

Regardless of the size and complexity of your installation, the planning time you spend up front can help streamline the installation and configuration of your fixtures. Keep these points in mind as you plan your installation:

- Create a lighting design plan that identifies and locates all fixtures, Data Enabler Pro devices, and controllers. Use this Product Guide and the online Configuration Calculator to determine whether to install fixtures in series or in parallel, how many fixtures you can install in a single run, and the maximum distances between Data Enabler Pro devices, fixtures, and controllers.
- To aid in addressing fixtures for color-changing light shows, record the serial number of each fixture as you assign it to your lighting design plan, and create a layout map that records the address or position of each fixture within a sequence of fixtures.
- Determine whether to address fixtures and configure your lighting system offline or interactively. With offline configuration, you stage and configure your system off-site, prior to installation. Offline configuration can be convenient when fixtures are to be installed in multiple locations or locations with difficult access. Interactive configuration is typically performed by an experienced technician, after fixtures have been installed. The interactive method can save time, since you connect and test your fixtures only once.

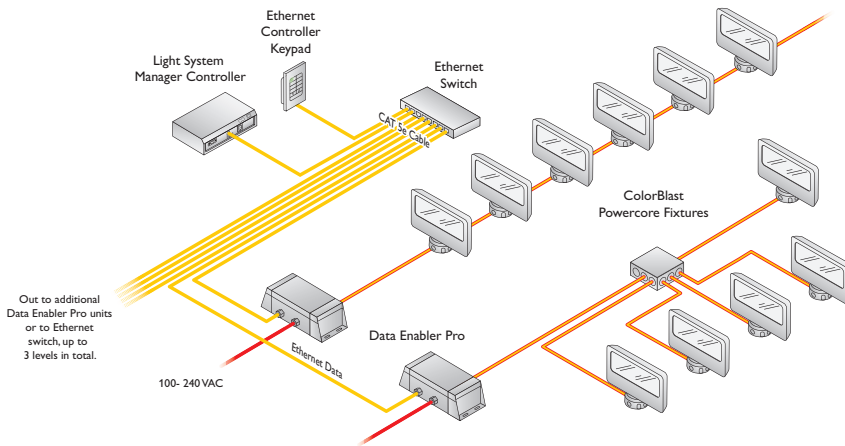

Large-scale Ethernet installation with Light System Manager

Large-scale installations may include multiple runs of ColorBlast Powercore fixtures controlled by Light System Manager. Each Data Enabler Pro supports a single run of fixtures, and connects to an available port on the Ethernet Switch.

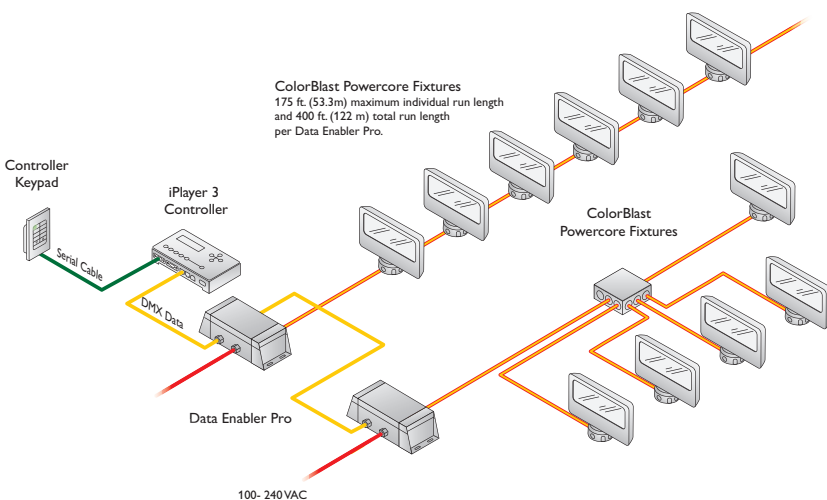

Small-scale DMX installation with iPlayer 3

Small-scale installations may feature one or more runs of ColorBlast Powercore fixtures controlled by iPlayer 3. Data Enabler Pro devices can be connected in series to one or both DMX output ports on the iPlayer 3.

Photometrics

Photometric data is based on test results from an independent NIST traceable testing lab. IES data is available at www.colorkinetics.com/support/ies.

ColorBlast Powercore 10° clear lens

LED	Lumens	Efficacy
RGB	1418	27.7

Polar Candela Distribution

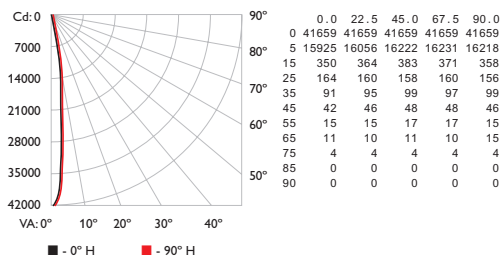

Illuminance at Distance

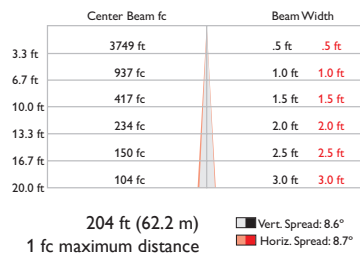

Zonal Lumen

ZONE	LUMENS	%FIXT
0- 30	1289	90.9
0- 40	1352	95.3
0- 60	1404	99.0
0- 90	1418	100.0
90-180	0	0.0
0-180	1418	100.0

Coefficients Of Utilization - Zonal Cavity Method

RC	Effective Floor Cavity Reflectance: 20%														
	80			70			50			30			10		
RW	70	50	30	10	70	50	30	10	50	30	10	50	30	10	0
0	119119119119	116116116116	1111111111	106106106	102102102	100									
1	116114112111	113112110109	108107106	104103103	101100100	98									
2	113110107105	111108106104	105103101	102101	99	99	98	97	96						
3	110106103101	108105102100	102100	98	100	98	97	98	97	95	94				
4	107103100	106102	99	97	100	98	96	98	96	95	97	95	94	93	
5	105101	97	95	104100	97	94	98	96	94	97	95	93	96	94	92
6	103	98	95	93	102	98	95	93	97	94	92	95	93	91	94
7	102	97	93	91	101	96	93	91	95	92	91	94	92	90	93
8	100	95	92	90	99	95	92	90	94	91	89	93	91	89	92
9	99	94	91	89	98	93	90	89	93	90	88	92	90	88	91
10	97	93	90	88	97	92	89	88	92	89	87	91	89	87	91

RCC %: Ceiling reflectance percentage, RW %: Wall reflectance percentage, RCR: Room cavity ratio

For lux multiply fc by 10.7

ColorBlast Powercore 23° frosted lens

LED	Lumens	Efficacy
RGB	1222	23.9

Polar Candela Distribution

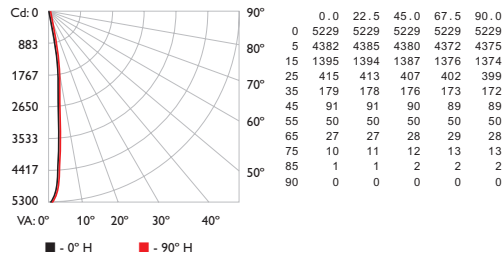

Illuminance at Distance

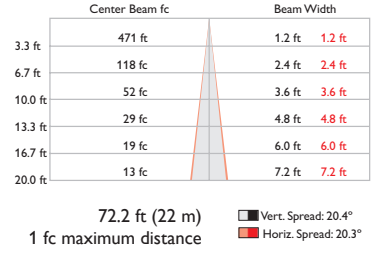

Zonal Lumen

ZONE	LUMENS	%FIXT
0- 30	950	77.8
0- 40	1062	87.0
0- 60	1179	96.5
0- 90	1222	100.0
90-180	0	0.0
0-180	1222	100.0

Coefficients Of Utilization - Zonal Cavity Method

RC	Effective Floor Cavity Reflectance: 20%														
	80			70			50			30			10		
RW	70	50	30	10	70	50	30	10	50	30	10	50	30	10	0
0	119119119119	116116116116	111111111	106106106	102102102	100									
1	1141111109107	111109107105	105103102	10110099	989796	94									
2	10910410097	1061029996	999694	969492	939290	88									
3	104989390	102979289	949188	928986	898785	83									
4	100938884	98928783	908682	888481	868381	79									
5	96888379	94878279	868178	848077	827977	75									
6	92847975	91837875	827874	817774	797673	72									
7	89807572	87807571	797471	787471	767370	69									
8	85777269	84777268	767168	757168	747068	66									
9	83746966	82746966	736966	726865	716865	64									
10	80726764	79716764	716663	706663	696663	62									

RCC %: Ceiling reflectance percentage, RW %: Wall reflectance percentage, RCR: Room cavity ratio

For lux multiply fc by 10.7

Specifications

Due to continuous improvements and innovations, specifications may change without notice.

Item	Specification	Details
Output	Beam Angle	10° / 23°
	Lumens*	1418 (10° clear lens) 1222 (23° frosted lens)
	LED Channels	Red / Green / Blue
	Mixing Distance	6 in (152 mm) to uniform light
	Lumen Maintenance	50,000+ hours L50 @ 50° C (full output)
Electrical	Input Voltage	100 – 240 VAC, auto-switching, 50 / 60 Hz via Data Enabler Pro
	Power Consumption	50 W maximum at full output, steady state
Control	Interface	Data Enabler Pro (DMX / Ethernet)
	Control System	Philips full range of controllers, including Light System Manager, iPlayer 3, and ColorDial Pro, or third-party controllers
Physical	Dimensions (Height x Width x Depth)	7.1 x 12.5 x 4.9 in (172 x 317 x 125 mm)
	Weight	6.4 lb (2.9 kg)
	Effective Projected Area (EPA)	0.05211 m ²
	Housing	Die-cast aluminium, powder-coated finish
	Lens	Clear tempered glass (10° beam angle) Frosted tempered glass (23° beam angle)
	Fixture Connections	6 ft (1.8 m) unified power / data cable
	Temperature Ranges	-40° – 122° F (-40° – 50° C) Operating -4° – 122° F (-20° – 50° C) Startup -40° – 176° F (-40° – 80° C) Storage
	Humidity	0 – 95%, non-condensing
	Fixture Run Lengths Per Data Enabler Pro†	30 @ 100 VAC Configuration: 36 @ 120 VAC 20 A circuit, 20 ft (6.1 m) leader cable from Data 66 @ 220 VAC Enabler Pro to first junction box, 2 ft (610 mm) 72 @ 240 VAC jumper cables
	Certification and Safety	Certification
Environment		Dry / Damp / Wet Location, IP66

* Lumen measurement complies with IES LM-79-08.



† These figures, provided as a guideline, are accurate for this configuration only. Changing the configuration can affect the fixture run lengths.

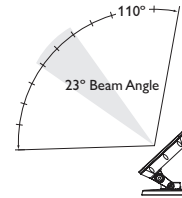
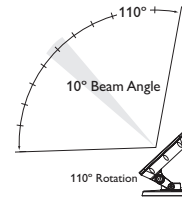

✳️ To calculate the number of fixtures your specific installation can support, download the Configuration Calculator from www.colorkinetics.com/support/install_tool

CHROMACORE[®] | OPTIBIN[®] | POWERCORE[®]
CKTECHNOLOGY | CKTECHNOLOGY | CKTECHNOLOGY

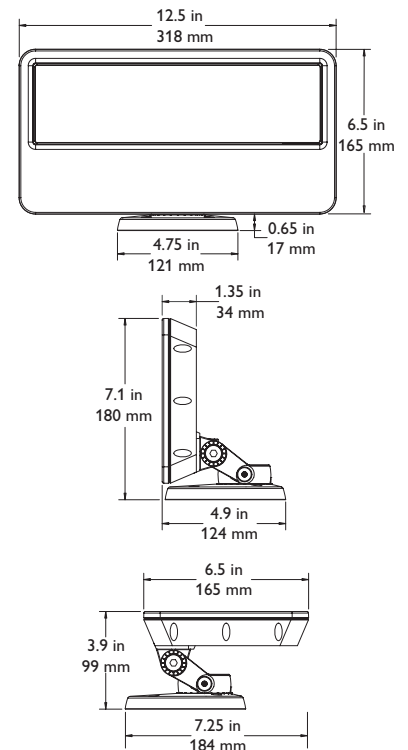

Fixtures and Data Enabler Pro

ColorBlast Powercore fixtures are part of a complete system which includes:

- One or more Data Enabler Pro devices
- Any Philips controller, including Light System Manager, iPlayer 3, and ColorDial Pro, or a third-party controller
- 4-conductor copper wire to connect ColorBlast Powercore fixtures in series or in parallel. Standard 12 AWG (2.05 mm) stranded wire is recommended.

Included in the box

ColorBlast Powercore fixture
(2) 8-32 screws for indoor installation
(4) 10-24 stainless steel screws for outdoor installation
1/8 in hex key wrench for fixture positioning and locking
Junction box gasket
Installation Instructions

ColorBlast Powercore fixtures

Item	Type	Housing Color	Item Number	Philips 12NC
ColorBlast Powercore UL / cUL / CE / PSE	10° clear lens	White	123-000021-00	910503702321
		Black	123-000021-01	910503702350
	23° frosted lens	White	123-000021-02	910503702334
		Black	123-000021-03	910503702351
ColorBlast Powercore CQC	10° clear lens	White	123-000021-08	910503702434
		Black	123-000021-09	910503702435
	23° frosted lens	White	123-000021-10	910503702436
		Black	123-000021-11	910503702437
Data Enabler Pro	3/4 in / 1/2 in NPT (US trade size conduit)		106-000004-00	910503701210
	PG21 / PG13 (metric size conduit)		106-000004-01	910503701211

Use Item Number when ordering in North America.

Typical ColorBlast Powercore installation

For detailed wiring diagrams visit www.colorkinetics.com/support/wiring/ls_prod.html

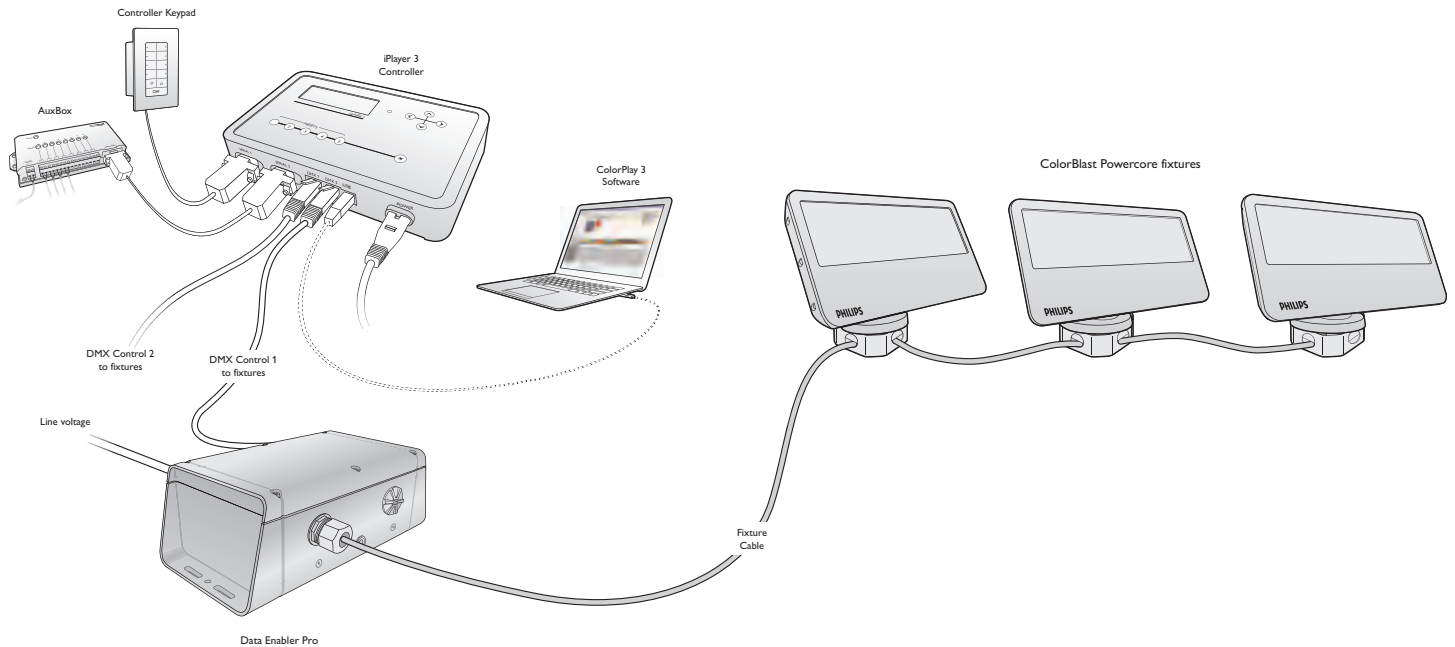

Accessories

Designed specifically for the family of Blast fixtures, accessories provide additional options for controlling and dispersing light. Accessory holders snap to the front of the fixture and are required for mounting accessories. Accessory holders prevent accessories from falling out if the fixture is tipped or hung upside down.

Item	Housing Color	Item Number	Philips 12NC	
Accessory Holders	White	120-000070-00	—	
	Black	120-000070-01	—	
Half Top Hats	White	120-000009-03	—	
	Black	120-000009-04	—	
Top Hats	White	120-000005-03	—	
	Black	120-000005-04	—	
Egg Crate Louvers	White	120-000015-03	—	
	Black	120-000015-04	—	
Barndoors	White	120-000019-03	—	
	Black	120-000019-04	—	
Horizontal Spread Lens	36 / 50°	120-000025-00	—	
Vertical Spread Lens	40°	120-000025-01	—	

Installation

ColorBlast Powercore offers rich, saturated wall-washing color and color-changing effects with Powercore technology. Powercore, which integrates LED power and data management within the fixture, eases installation by eliminating the need for external power supplies.

Owner / User Responsibilities

It is the responsibility of the contractor, installer, purchaser, owner, and user to install, maintain, and operate ColorBlast Powercore fixtures in such a manner as to comply with all applicable codes, state and local laws, ordinances, and regulations. Consult with the appropriate electrical inspector to ensure compliance.

Installing in Damp or Wet Locations

When installing in damp or wet locations, it is good practice to seal all fixtures and junction boxes with electronics-grade RTV silicone sealant to ensure that moisture cannot enter or accumulate in wiring compartments, cables, or other electrical parts. You must use suitable outdoor-rated junction boxes when installing in damp or wet locations. Additionally, you must use gaskets, clamps, and other parts required for installation to comply with all applicable local and national codes

✳ Refer to the ColorBlast Powercore Installation Instructions for specific warning and caution statements.

Create a Lighting Design Plan and Layout Grid

1. Determine the appropriate location of each Data Enabler Pro in relation to the light fixtures, and of the light fixtures in relation to each other.

ColorBlast Powercore fixtures can be installed in series or in parallel (wired to a common junction box). The maximum number of fixtures each Data Enabler Pro can support depends on specific configuration details such as fixture spacing, circuit size, line voltage, and method of connection (in series or in parallel). As an example, the table to the left lists the maximum number of fixtures each Data Enabler Pro can support at various voltages, assuming a 20A circuit, a 20 ft (6.1 m) leader cable from Data Enabler Pro to first junction box, and 2 ft (610 mm) jumper cables between fixtures. Keep in mind that these figures, provided as a guideline, are accurate for the specified configuration only. Changing the configuration can affect the fixture run lengths.

Fixture run lengths

30 @ 100 VAC
36 @ 120 VAC
66 @ 220 VAC
72 @ 240 VAC

assuming 20 A circuit, 20 ft (6.1 m) leader cable from Data Enabler Pro to first junction box, 2 ft (610 mm) jumper cables

✳ For more information, and for help calculating the number of fixtures your specific installation can support, download the Configuration Calculator from www.colorkinetics.com/support/install_tool/, or consult Application Engineering Services at support@colorkinetics.com.

In addition to maximum fixture run lengths determined by the electrical configuration, each Data Enabler Pro imposes maximum run lengths based on data integrity. To ensure data integrity, maximum individual run length should not exceed 175 feet (53.3 m), and the total cable length per Data Enabler Pro should not exceed 400 feet (122 m).

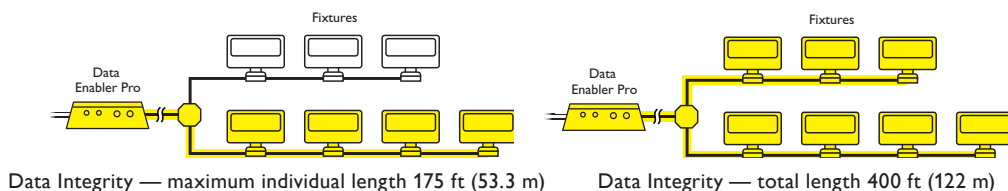

Leader Cable connector dimensions

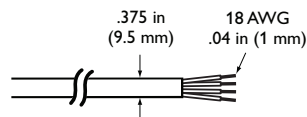

2. On an architectural diagram or other diagram that shows the physical layout of the installation, identify the locations of all switches, controllers, Data Enabler Pro devices, fixtures, and cables.

- Each ColorBlast Powercore fixture comes pre-programmed with a unique serial number. As you unpack the fixtures, record the serial numbers in a layout grid (typically a spreadsheet or list) for easy reference and light addressing.
- Assign each fixture to a position in the lighting design plan.
- To streamline installation and aid in light show programming, you can affix a weatherproof label identifying the order or placement in the installation to an inconspicuous location on each light fixture's housing.

Start the Installation

- Install all Data Enabler Pro devices, including any interfaces with controllers. Data Enabler Pro devices and external controllers send power and control signals to the fixtures over the single fixture cable. Additional cabling is required to connect fixtures together in series.
- Verify that all additional supporting equipment (switches, controllers) is in place.
- Ensure that all additional parts and tools are available, including:
 - The included 8-32 screws for indoor installations, or the 10-24 stainless steel screws for outdoor installations
 - The included 1/8 hex key wrench
 - The included junction box gasket
 - In the US, one 4 in (102 mm) round US electrical junction box per fixture, rated for your application, with 3.5 in (89 mm) center-to-center screw holes for attaching the fixture's base. (Refer to the junction box manufacturer's literature for additional items required for mounting or sealing.)
 - A sufficient length of 12 AWG (2.05 mm), 4-conductor stranded copper wire
 - Conduit as required
 - Electronics-grade room temperature vulcanizing (RTV) silicone sealant

Install the Fixtures

ColorBlast Powercore fixtures can be installed in series or in parallel (wired to a common junction box). Each fixture requires a dedicated junction box for mounting. Ensure that all junction boxes are suitable for the environment and sealed, if necessary, and that all wiring between junction boxes complies with local codes.

Make sure the power is OFF before mounting and connecting ColorBlast Powercore fixtures.

- Mount junction boxes in accordance with the lighting design plan. Each fixture is designed for mounting in a 4 in (102 mm) round US electrical junction box, rated for your application, with 3.5 in (89 mm) center-to-center screw holes for attaching the fixture's base.
- If installing fixtures in a series, pull 4-conductor copper wire between each junction box in the series.

If installing fixtures in parallel, pull 4-conductor copper wire from a common junction box to each fixture's junction box.

The maximum cable run from a Data Enabler Pro to any individual ColorBlast Powercore fixture is 175 feet (53 m). When installing in parallel, the total cable length cannot exceed 400 feet (122 m).

Record fixture serial numbers

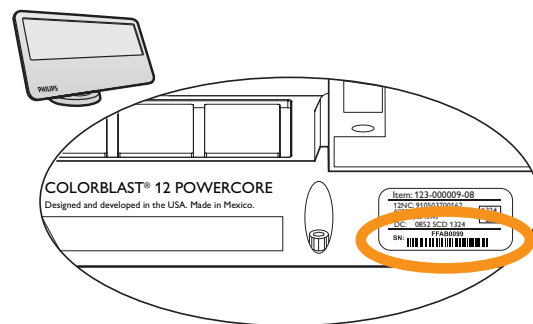

✳ For complete instructions on how to wire the Data Enabler Pro, refer to the Data Enabler Pro Product Guide or Installation Instructions.

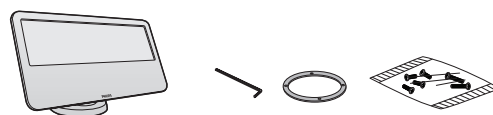

Included in the box

ColorBlast Powercore fixture
(2) 8-32 screws for indoor installation
(4) 10-24 stainless steel screws for outdoor installation
1/8 in hex key wrench for fixture positioning and locking
Junction box gasket
Installation Instructions

✳ When installing ColorBlast Powercore fixtures, the input earth ground, canopy earth ground, and fixture cable earth ground must all be connected together.

✳ In locations where US junction boxes are not available, you can mount fixtures directly to a wall or other mounting surface. For help with your specific installation, consult your local support organization, or contact Application Engineering Services at support@colorkinetics.com.

✳ Wiring between junction boxes must comply with local codes.

Install fixtures in series or in parallel

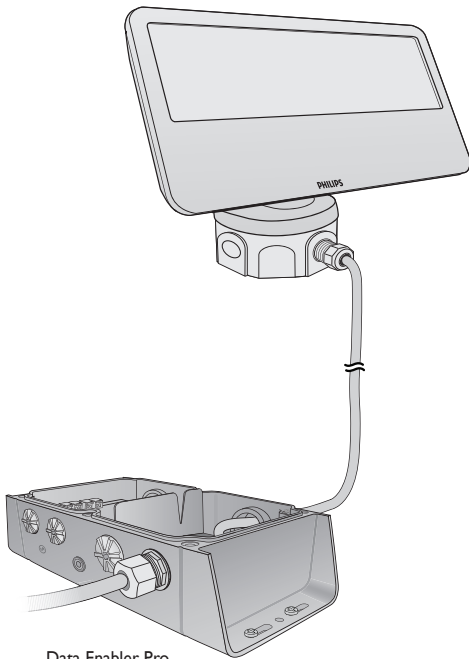
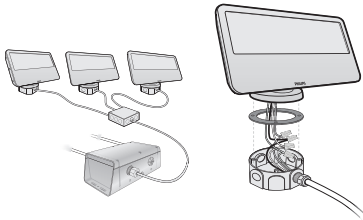
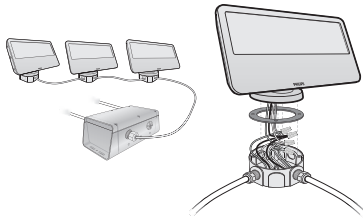

Data Enabler Pro

3. Trim the cable from the fixture to fit in the junction box, leaving enough cable to make wiring connections.
4. Insert the fixture cable through the provided junction box gasket before making wire connections. When attaching the fixture to the junction box, ensure that the gasket is compressed evenly.
5. Use wire nuts to connect line, neutral, ground, and data. If installing in series, connect the leader cable from each fixture to the fixture's junction box. If installing in parallel, connect the leader cable from each fixture to the lead wire from the Data Enabler Pro in the common junction box.
6. Tuck wire connections into the junction box, and use the provided screws to attach the fixture to the junction box.
7. If installing in a wet or damp location, seal all junction boxes with electronics-grade RTV silicone sealant. Use gaskets, clamps, and other parts and fittings required to comply with local outdoor wiring codes.

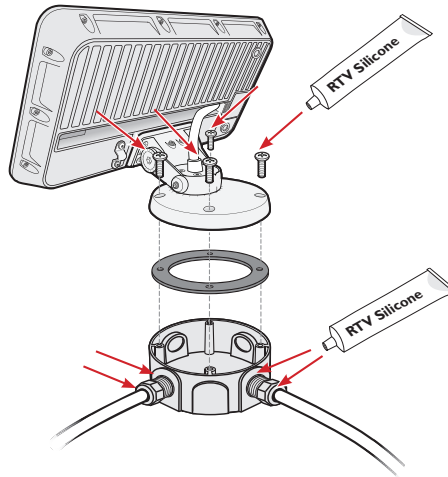

8. Run the wiring from the first junction box in the series to the Data Enabler Pro, or, if installing in parallel, run the wiring from the common junction box to the Data Enabler Pro. Secure connections within the Data Enabler Pro housing.
9. Secure the Data Enabler Pro cover. If installing in a wet or damp location, seal the Data Enabler Pro with electronics-grade RTV silicone sealant.

Power / data output to fixtures

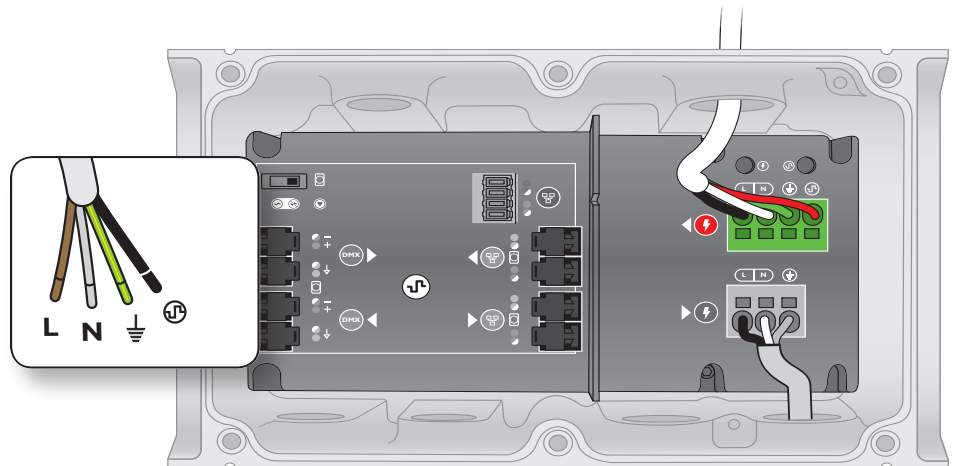

Mains voltage output

* Refer to the Data Enabler Pro Product Guide for comprehensive installation and configuration instructions. You can view or download the guide from www.colorkinetics.com/lspds/dataenablerpro

Attach Safety Cable (optional)

Each ColorBlast Powercore fixture is designed for use with a safety cable to tether it to a secure anchor point. When dictated by local or state code or advised by a structural engineer, attach a safety cable to the bracket on the back of the fixture. Remove the two screws that attach the cable bracket, loop the safety cable over the cable bracket, and reattach to the fixture. Attach the safety cable to the mounting surface using a method that follows the code or engineer's requirements.

Address and Configure the Fixtures

Make sure the power is ON before addressing and configuring fixtures.

Each ColorBlast Powercore fixture uses three sequential DMX channels or addresses, one for red, one for green, and one for blue. ColorBlast Powercore fixtures come factory-addressed to DMX channels 1 (red), 2 (green), and 3 (blue).

For lighting designs where fixtures work in unison, all fixtures can be assigned the same DMX addresses. Changes to the default addresses are not necessary, but if lights were previously readdressed for use in other installations, you must reset them. For light show designs that show different colors on different fixtures, you must assign unique DMX addresses to your fixtures and sort them in a useful order.

- In Ethernet installations, you can address and configure your fixtures using QuickPlay Pro with a computer connected to your lighting installation's network. QuickPlay Pro can automatically discover all of your fixtures, controllers, and Data Enabler Pro devices for quick configuration.
- In DMX installations, you can address and configure your fixtures using QuickPlay Pro with iPlayer 3 or SmartJack Pro. You can manually enter fixture serial numbers, or you can import a spreadsheet listing each fixture's serial number and starting DMX address.

For complete details on addressing and configuring fixtures, controllers, and power / data supplies with QuickPlay Pro, refer to the *Addressing and Configuration Guide*, which you can view or download at www.colorkinetics.com/support/addressing.

Aim and Lock the Fixtures

Using the provided 1/8 in hex key wrench, loosen the rotation and tilting set screws. Aim the fixtures by rotating the base and tilting the beam as desired. Tighten the two pairs of set screws to lock the fixture in place.

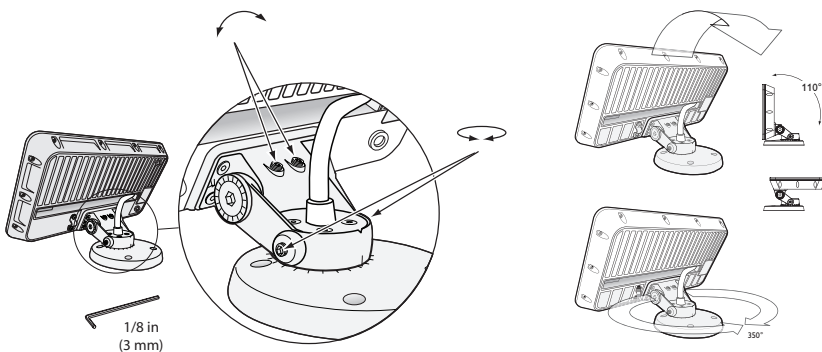

Safety cable bracket location on fixture

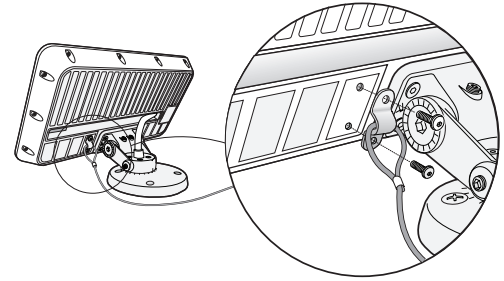

Safety cable minimum requirements

Material	316 Stainless Steel
Size	5/64 to 3/16 in (2 to 5 mm) nominal diameter. Minimum break load must be greater than 400 lb (181 kg)
Construction	7 x 7 (49 wires) preformed stranded

* You can download QuickPlay Pro from www.colorkinetics.com/support/addressing/

* You will need the layout grid that you created when you recorded the serial numbers of the light fixtures in your installation.



Philips Color Kinetics
3 Burlington Woods Drive
Burlington, Massachusetts 01803 USA
Tel 888.385.5742
Tel 617.423.9999
Fax 617.423.9998
www.philipscolorkinetics.com

Copyright © 2008 - 2011 Philips Solid-State Lighting Solutions, Inc. All rights reserved. Chromacore, Chromasic, CK, the CK logo, Color Kinetics, the Color Kinetics logo, ColorBlast, ColorBlaze, ColorBurst, ColorGraze, ColorPlay, ColorReach, iW Reach, eW Reach, eW Fuse, DIMand, EssentialWhite, eW, iColor, iColor Cove, IntelliWhite, iW, iPlayer, Optibin, and Powercore are either registered trademarks or trademarks of Philips Solid-State Lighting Solutions, Inc. in the United States and / or other countries. All other brand or product names are trademarks or registered trademarks of their respective owners. Due to continuous improvements and innovations, specifications may change without notice.
Cover Photo: Courtesy of Los Angeles World Airports

DAS-000008-00 R05 05-11